

- SF -

SHOP FRONT

62 SERIES

| PROFILE NO. | PICTURE OF PROFILE | WEIGHT (KG/M) | THICKNESS | PACKING IN BUNDLE (PCS) |
|-------------|--------------------|---------------|-----------------------|-------------------------|
| | | | AREA PERIMETER | |
| SF 6201 | | 0.743 | 1.10 MM 454.253 MM | 4 |
| SF 6203 | | 0.653 | 1.10 MM 405.857 MM | 4 |
| SF 6206 | | 0.264 | 1.00 MM 156.336 MM | 20 |
| SF 6207 | | 0.340 | 1.10 MM 198.224 MM | 10 |
| SF 6208 | | 1.076 | 1.25 MM 318.188 MM | 3 |
| SF 6209 | | 0.965 | 1.25 MM 279.401 MM | 3 |
| SF 6210 | | 0.380 | 2.15 MM 129.480 MM | 10 |
| SF 6211 | | 1.565 | 1.50 MM 381.688 MM | 2 |
| SF 6212 | | 1.378 | 1.40 MM 354.286 MM | 3 |
| SF 6213 | | 1.045 | 1.40 MM 515.49 MM | 4 |
| SF 6214 | | 0.268 | 1.00 MM 183.95 MM | 20 |
| SF 6215 | | 1.550 | 1.40 MM 415.371 MM | 3 |
| SF 6216 | | 1.156 | 1.40 MM 580.10 MM | 4 |

All Profiles are standard length 6.1 M for SF Series

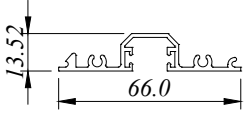
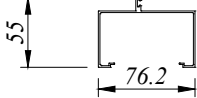
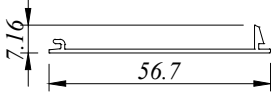
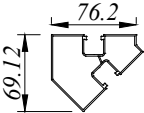
| PROFILE NO. | PICTURE OF PROFILE | WEIGHT (KG/M) | THICKNESS | PACKING IN BUNDLE (PCS) |
|-------------|---|---------------|-----------------------|-------------------------|
| | | | AREA PERIMETER | |
| SF 6217 |  | 0.534 | 1.40 MM 254.06 MM | 10 |
| SF 6218 |  | 0.720 | 1.20 MM 409.837 MM | 4 |
| SF 6219 |  | 0.195 | 1.00 MM 135.992 MM | 20 |
| SF 6220 |  | 1.193 | 1.25 MM 339.733 MM | 4 |
| | | | | |
| | | | | |
| | | | | |
| | | | | |
| | | | | |
| | | | | |
| | | | | |
| | | | | |
| | | | | |
| | | | | |
| | | | | |

All Profiles are standard length 6.1 M for SF Series

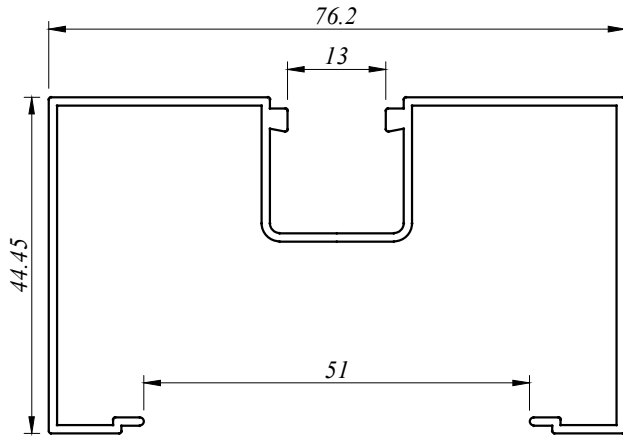

SF 6201
0.743 Kg/M
AP : 454.253 MM

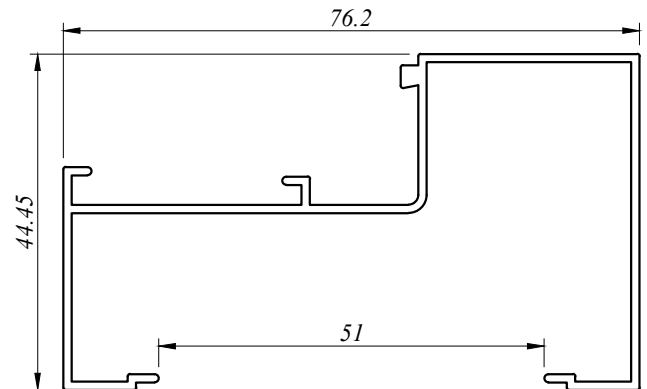

SF 6203
0.653 Kg/M
AP : 405.857 MM

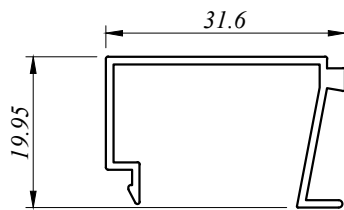

SF 6206
0.264 Kg/M
AP : 156.336 MM

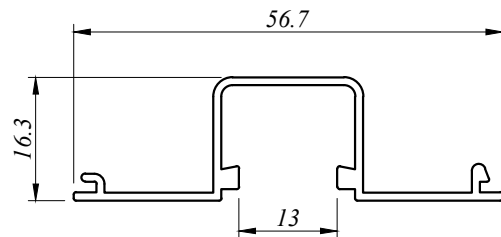

SF 6207
0.340 Kg/M
AP : 198.224 MM

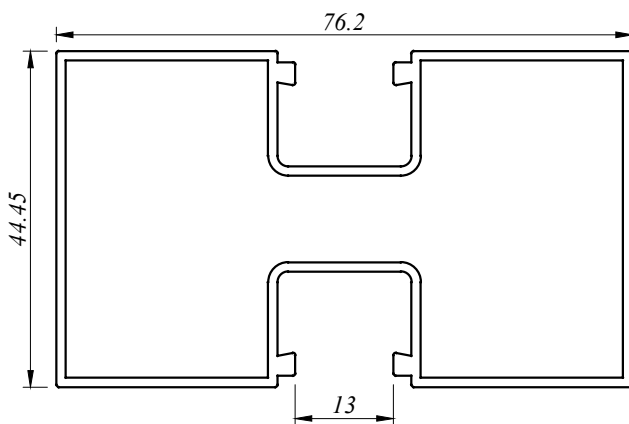

SF 6208
1.076 Kg/M
AP : 318.188 MM

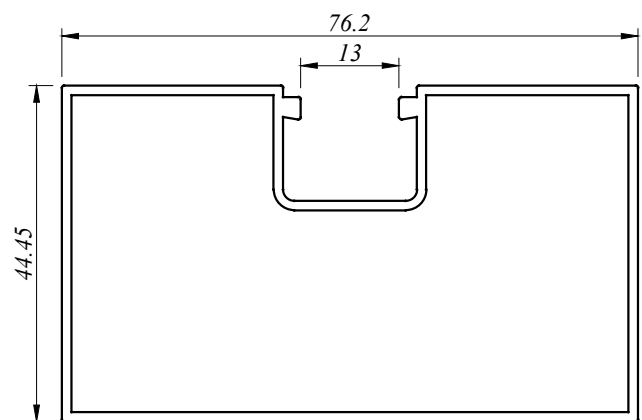

SF 6209
0.965 Kg/M
AP : 279.401 MM

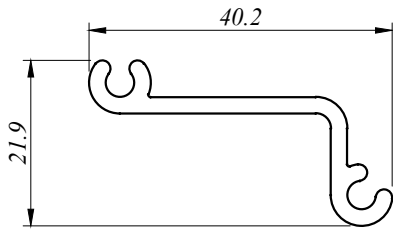

SF 6210
0.380 Kg/M
AP : 129.480 MM

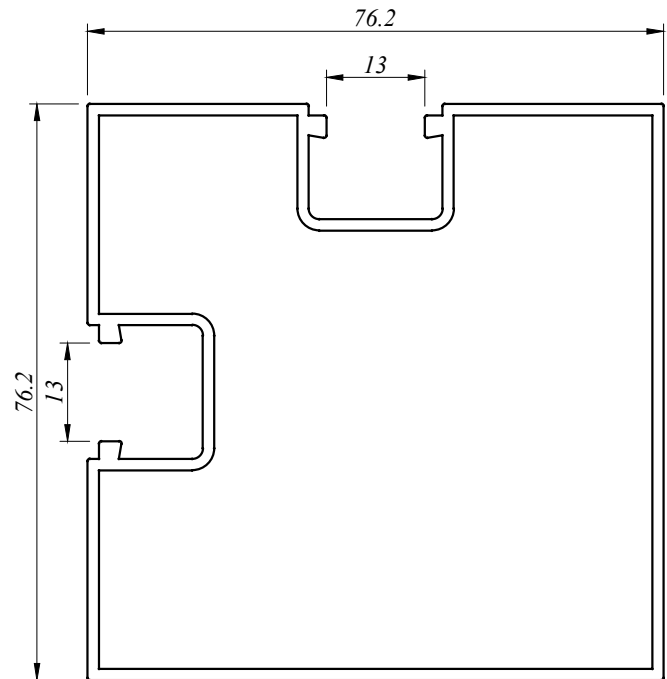

SF 6211
1.565 Kg/M
AP : 381.688 MM

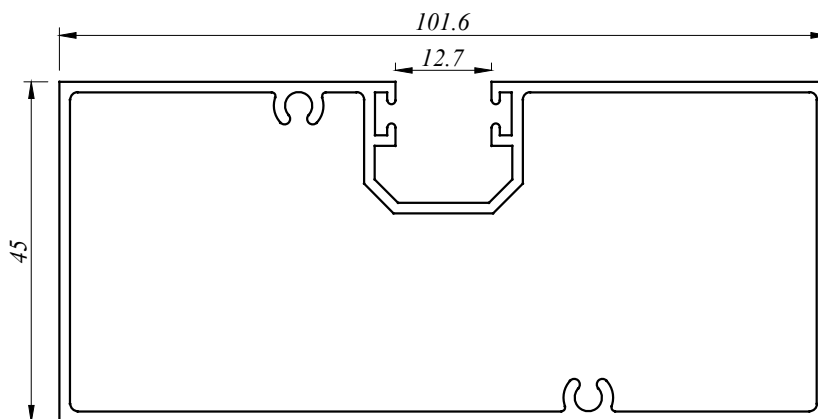

SF 6212
1.378 Kg/M
AP : 354.286 MM

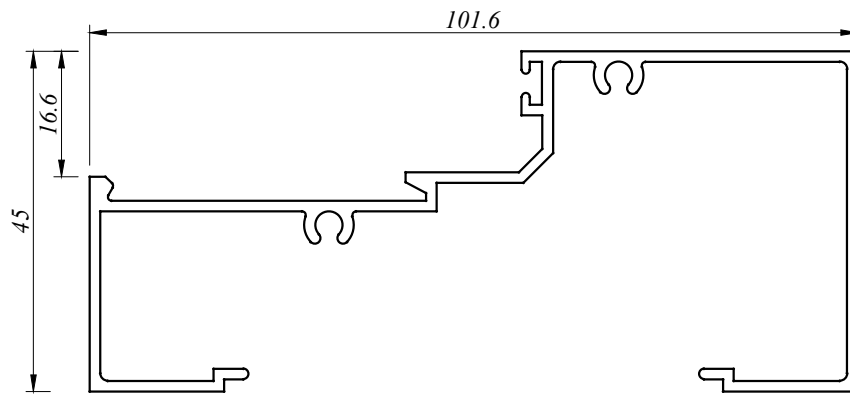

SF 6213
1.045 Kg/M
AP : 515.49 MM

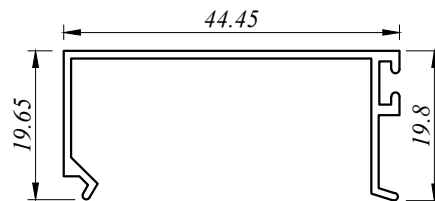

SF 6214
0.268 Kg/M
AP : 183.95 MM

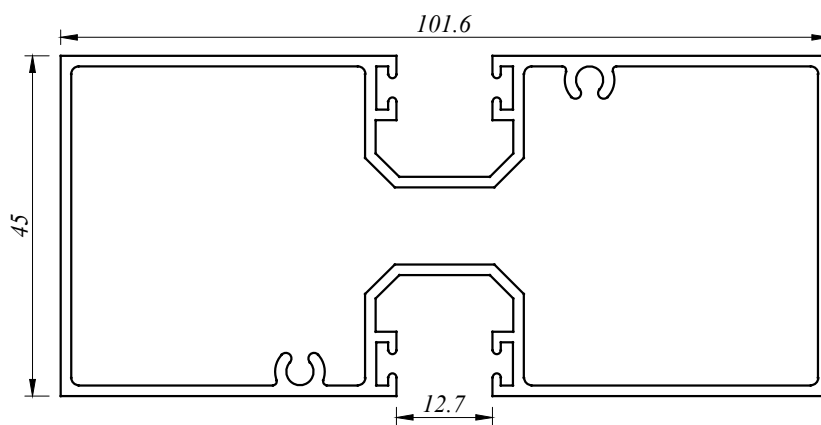

SF 6215
1.550 Kg/M
AP : 415.371 MM

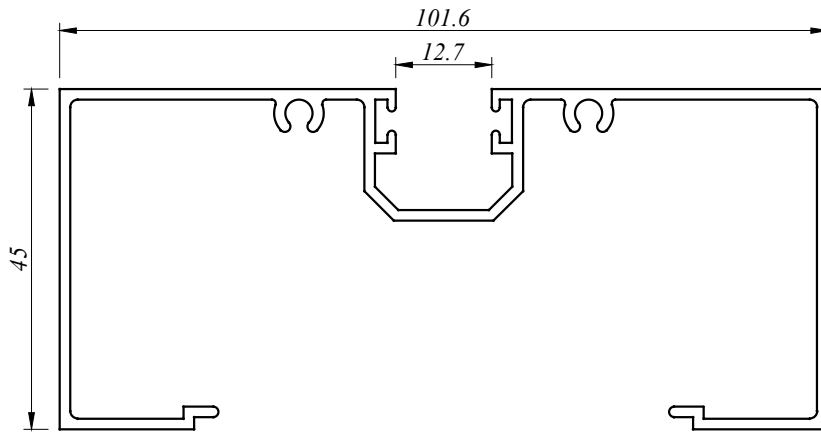

SF 6216
1.156 Kg/M
AP : 580.10 MM

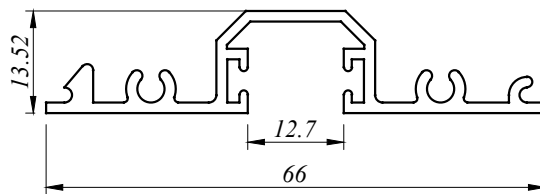

SF 6217
0.534 Kg/M
AP : 254.06 MM

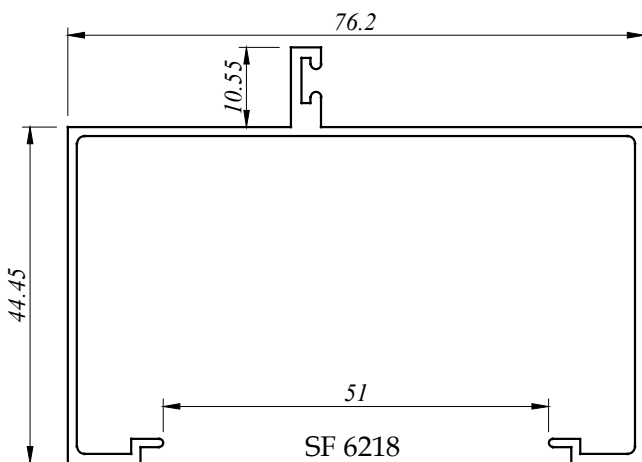

SF 6218
0.720 Kg/M
AP : 409.837 MM

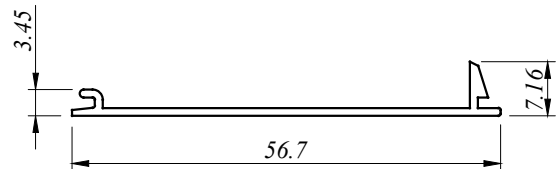

SF 6219
0.195 Kg/M
AP : 135.992 MM

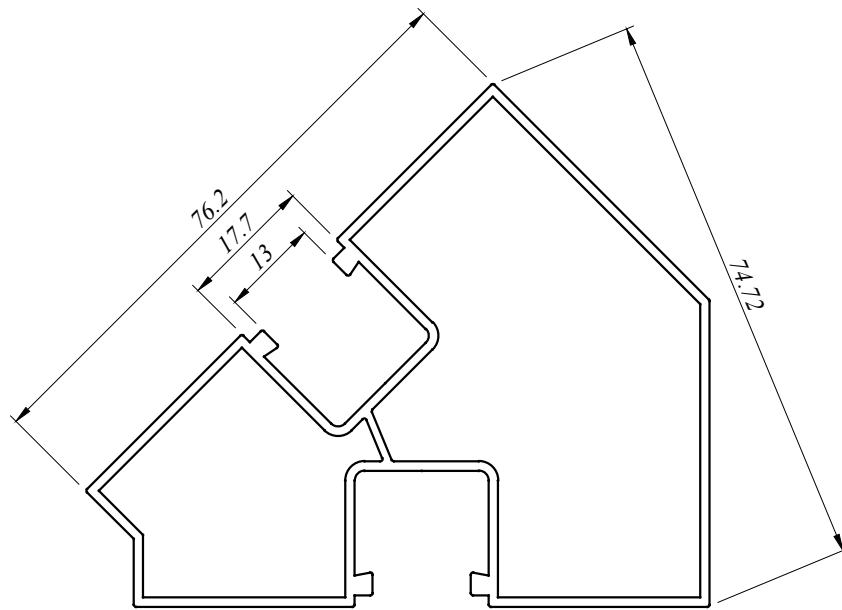

SF 6220
1.193 Kg/M
AP : 339.733 MM

aluminium profiles component usage

Shop Front - SF 62 Series

ASSEMBLY DRAWING

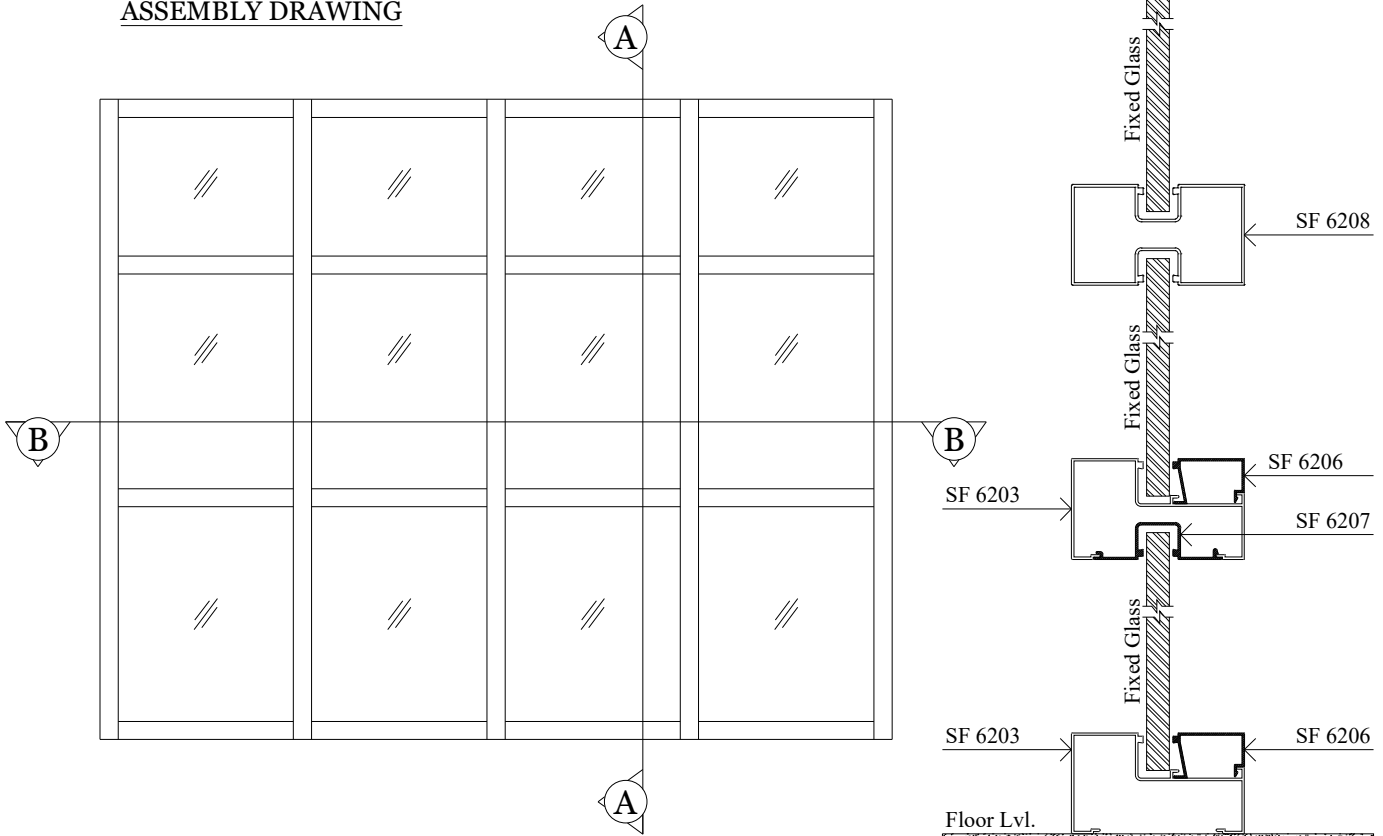

SECTION VIEW A - A

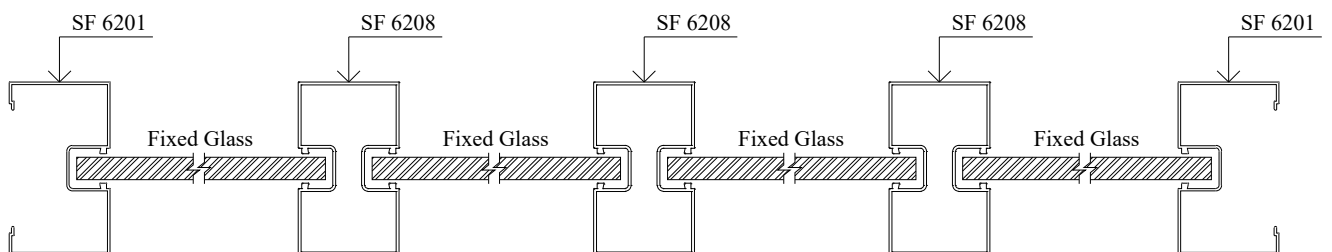

SECTION VIEW B - B



BP Aluminium Extrusion Sdn. Bhd.

No.15 & 16, 1C KKIP Selatan, Industrial Zone 2, KKIP,
88450, Jalan Sepanggar, Menggatal.

t : 60-88-499333, 499111 f : 60-88-499222

b_p_a_e@yahoo.com