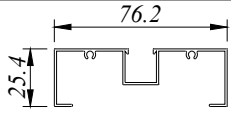
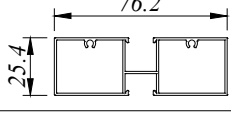
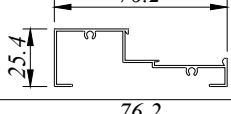
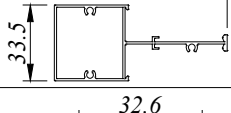
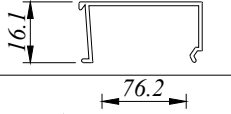
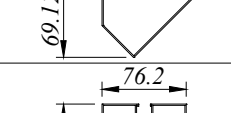
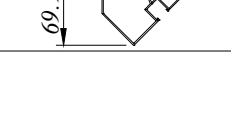

- SF -

***SHOP FRONT***

***61 SERIES***

PROFILE NO.	PICTURE OF PROFILE	WEIGHT (KG/M)	THICKNESS	PACKING IN BUNDLE (PCS)
			AREA PERIMETER	
SF 6101		0.514	1.00 MM 370.808 MM	6
SF 6102		0.698	1.00 MM 268.690 MM	4
SF 6103		0.448	1.00 MM 317.381 MM	6
SF 6104		0.599	1.00 MM 268.664 MM	4
SF 6105		0.182	1.00 MM 135.344 MM	20
SF 6112		0.804	1.20 MM 250.998 MM	2
SF 6113		1.106	1.20 MM 327.363 MM	2

All Profiles are standard length 6.1 M for SF Series

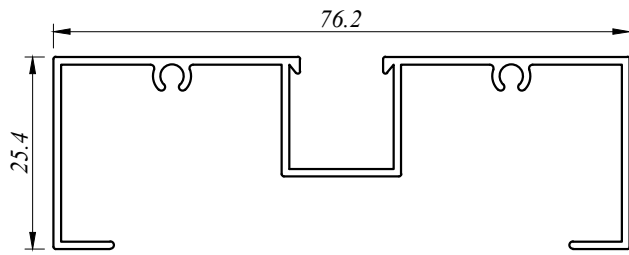

SF 6101  
0.514 Kg/M  
AP : 370.808 MM

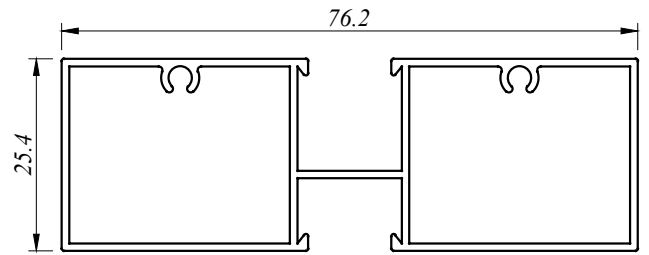

SF 6102  
0.698 Kg/M  
AP : 268.690 MM

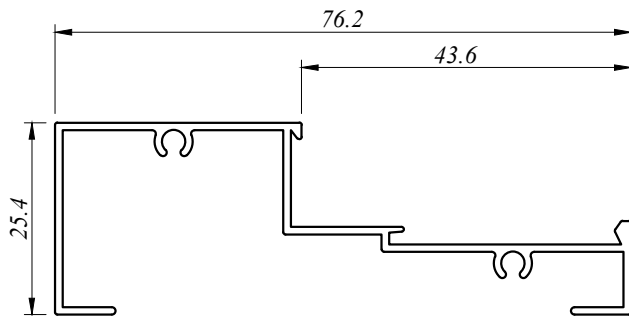

SF 6103  
0.448 Kg/M  
AP : 317.381 MM

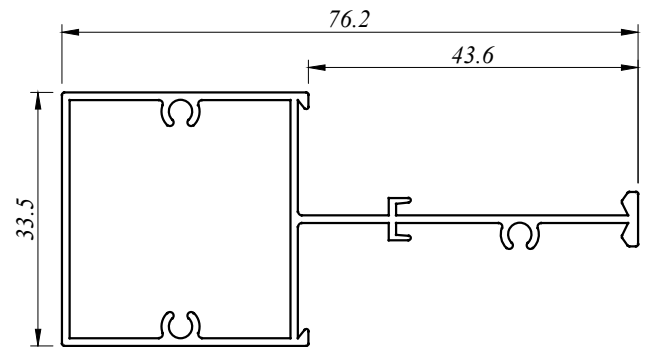

SF 6104  
0.599 Kg/M  
AP : 268.664 MM

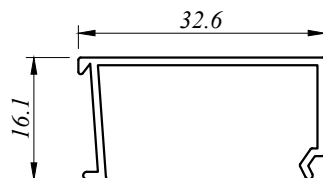

SF 6105  
0.182 Kg/M  
AP : 135.344 MM

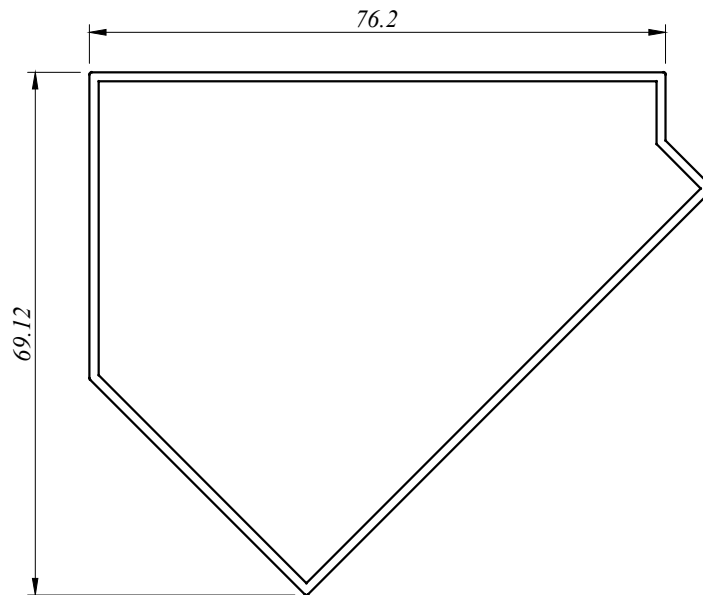

SF 6112  
0.804 Kg/M  
AP : 250.998 MM

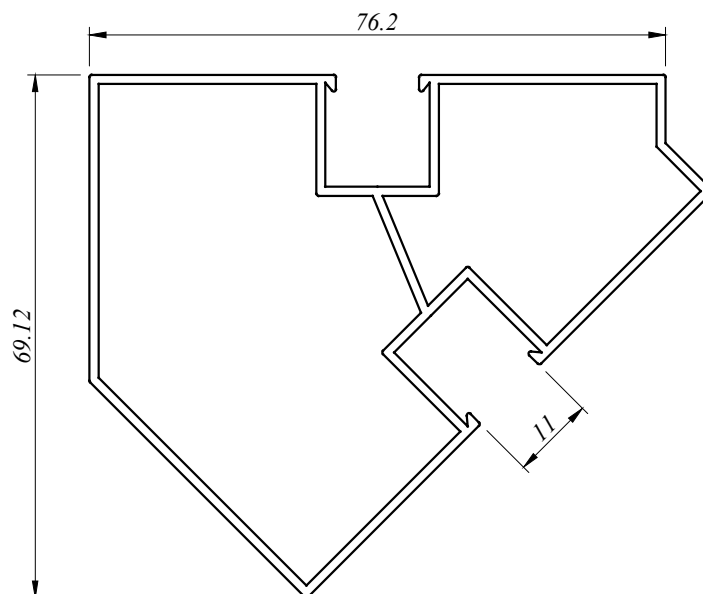

SF 6113  
1.106 Kg/M  
AP : 327.363 MM

# aluminium profiles component usage

## Shop Front - SF 61 Series

ASSEMBLY DRAWING

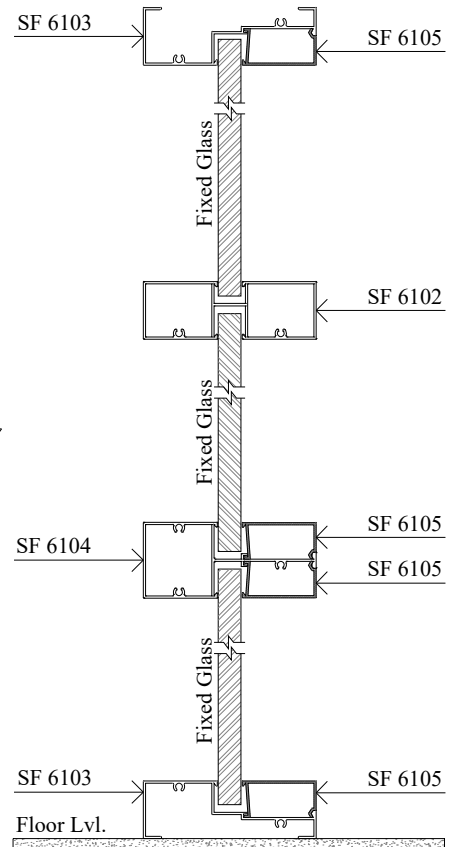
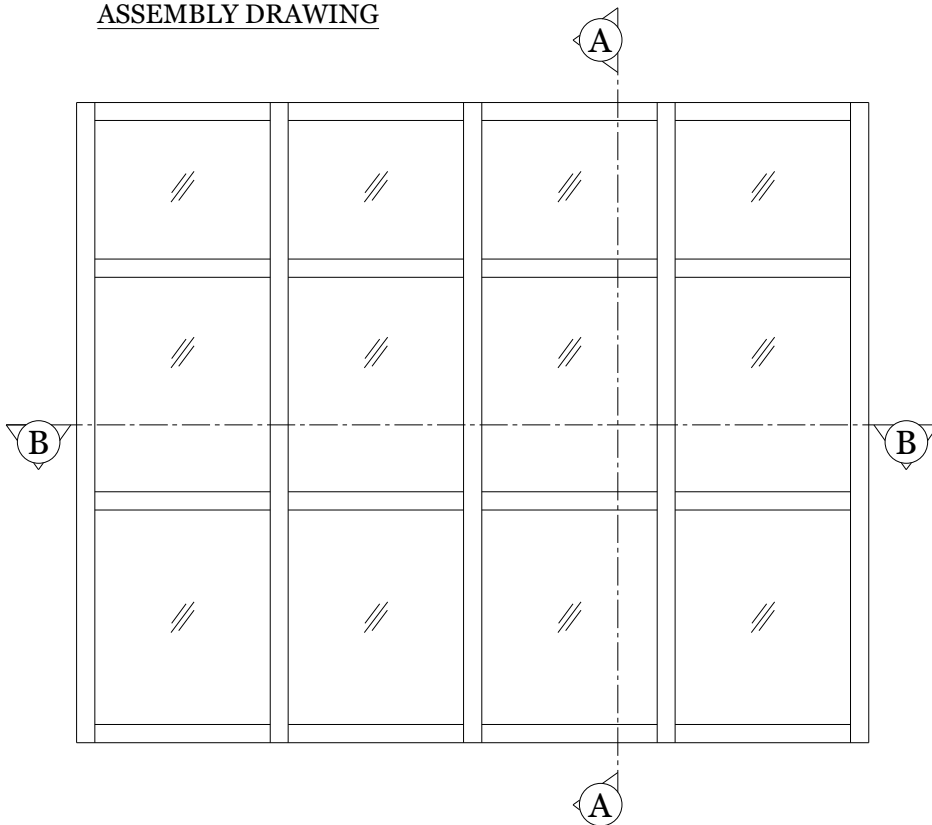

SECTION VIEW A - A

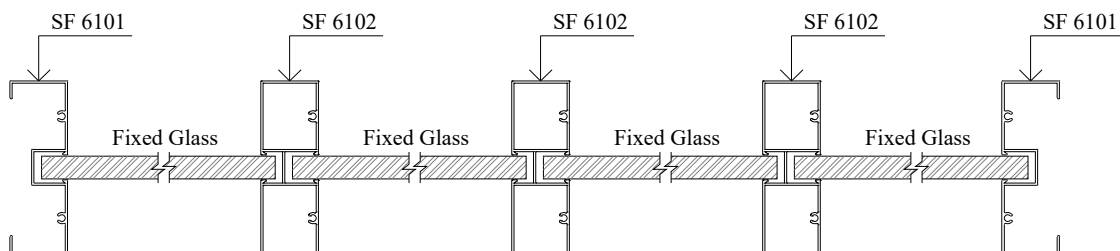

**BP Aluminium Extrusion Sdn. Bhd.**

**No.15 & 16, 1C KKIP Selatan, Industrial Zone 2, KKIP,  
88450, Jalan Sepanggar, Menggatal.**

**t : 60-88-499333, 499111 f : 60-88-499222**

**b\_p\_a\_e@yahoo.com**