

*MSL - M Sliding Window*  
*8 SERIES*

PROFILE NO.	PICTURE OF PROFILE	WEIGHT (KG/M)	THICKNESS	PACKING IN BUNDLE (PCS)
			AREA PERIMETER	
MSL 81020		0.867	1.20 MM 332.970 MM	4
MSL 81040		0.271	1.20 MM 169.108 MM	10
MSL 82010		0.986	1.20 MM 423.170 MM	4
MSL 82012		1.416	1.20 MM 665.674 MM	4
MSL 82041		0.172	1.20 MM 121.761 MM	20

*All Profiles are standard length 6.1 M for MSL Series*

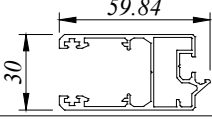
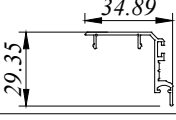
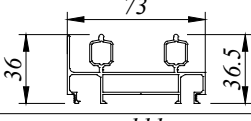
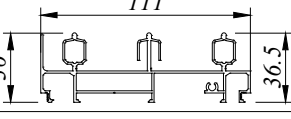
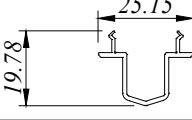
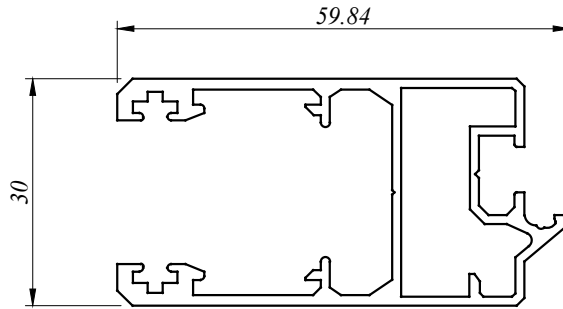

MSL 81020  
0.867 Kg/M  
AP : 332.970 MM

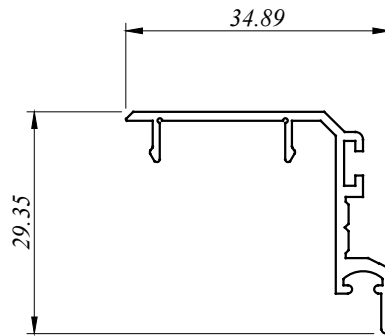

MSL 81040  
0.271 Kg/M  
AP : 169.108 MM

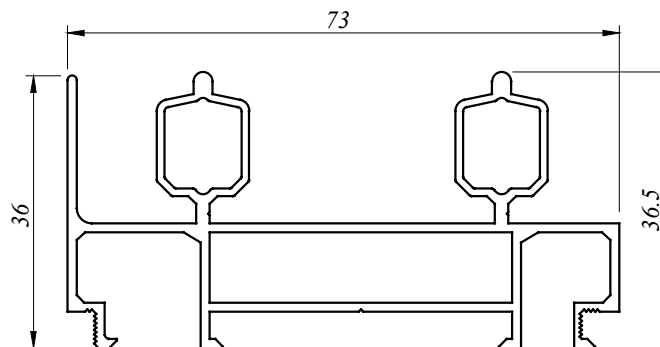

MSL 82010  
0.986 Kg/M  
AP : 423.170 MM

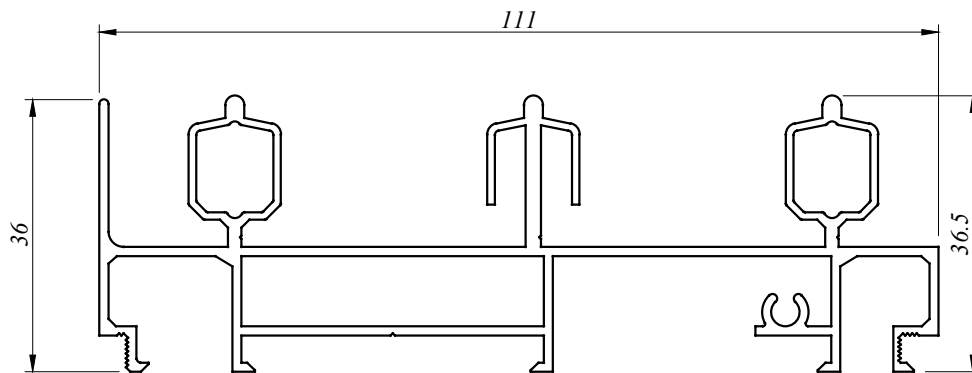

MSL 82012  
1.416 Kg/M  
AP : 665.674 MM

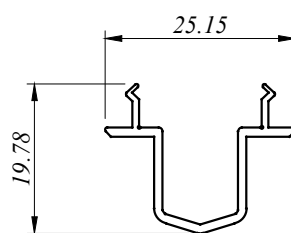

MSL 82041  
0.172 Kg/M  
AP : 121.761 MM

# aluminium profiles component usage

## M Sliding Window - MSL 8 Series

### **MSL - SLIDING WINDOW**

Size : 1800mm (w) x 1200mm (h)

Type : Aluminium frame light tinted glass sliding window.

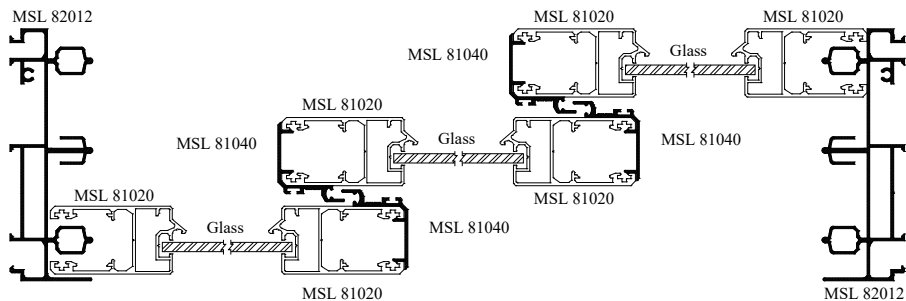
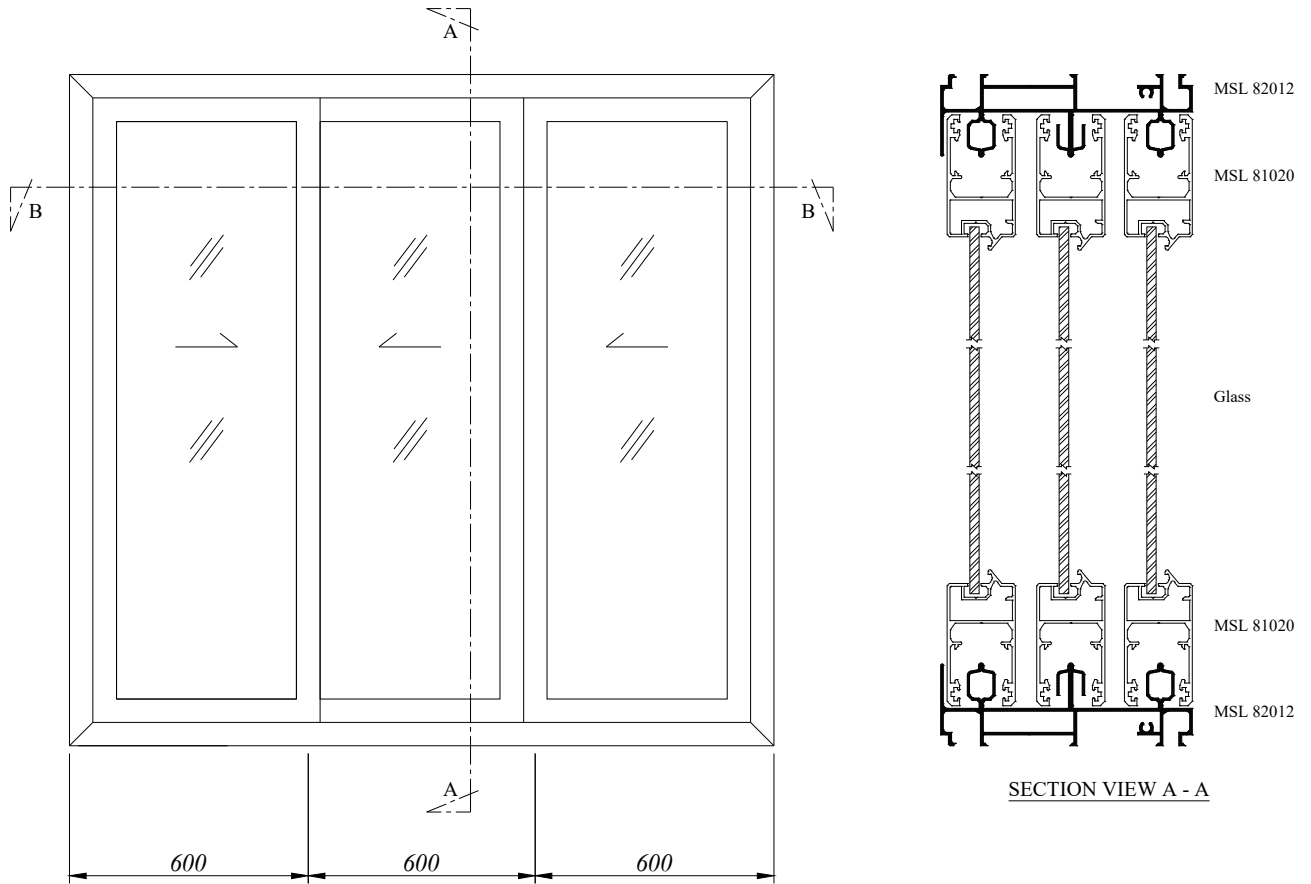

SECTION VIEW B - B

**we made aluminium into shapes ...**

*profile information*

# aluminium profiles component usage

## M Sliding Window - MSL 8 Series

### MSL - SLIDING WINDOW

Size : 1200mm (w) x 1200mm (h)

Type : Aluminium frame light tinted  
glass sliding window.

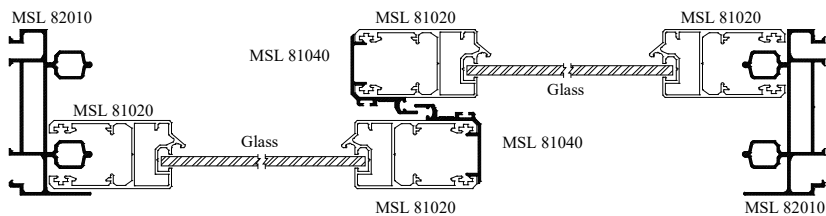
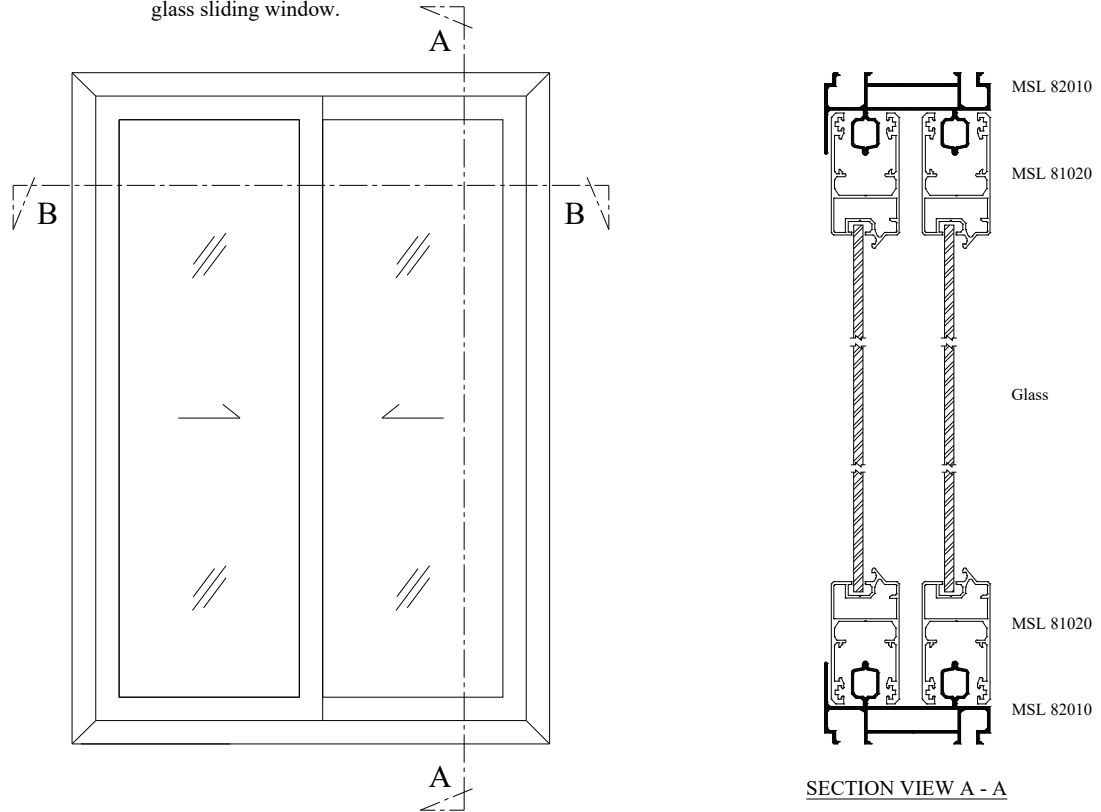

SECTION VIEW B - B

UPDATE : 13/09/22



**BP Aluminium Extrusion Sdn. Bhd.**

**No.15 & 16, 1C KKIP Selatan, Industrial Zone 2, KKIP,  
88450, Jalan Sepanggar, Menggatal.**

**t : 60-88-499333, 499111 f : 60-88-499222**

**b\_p\_a\_e@yahoo.com**