

SWD - Swing Door
460 SERIES

PROFILE NO.	PICTURE OF PROFILE	WEIGHT (KG/M)	THICKNESS	PACKING IN BUNDLE (PCS)
			AREA PERIMETER	
SWD 4601		1.070	1.35 MM 322.414 MM	3
SWD 4602		0.841	1.30 MM 254.527 MM	4
SWD 4603		0.763	1.30 MM 246.091 MM	4
SWD 4604		0.139	1.00 MM 102.628 MM	24
SWD 4605		1.047	1.40 MM 284.753 MM	3
SWD 4608		1.292	1.30 MM 395.424 MM	3
SWD 4609		0.952	1.30 MM 274.455 MM	4
SWD 4610		1.187	1.20 MM 280.360 MM	3
SWD 4611		0.750	1.10 MM 232.227 MM	-
SWD 4612		0.897	1.50 MM 245.638 MM	-

All Profiles are standard length 6.1 M for SWD Series
Except SWD 4603 which is 4.34M & 4.88M

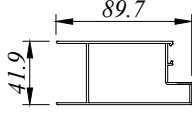
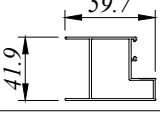
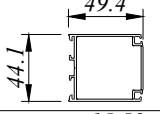
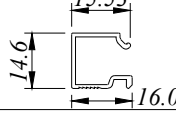
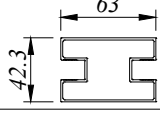
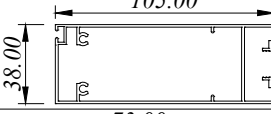
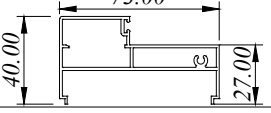
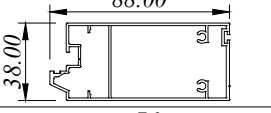
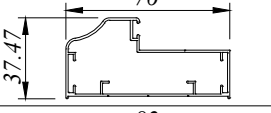
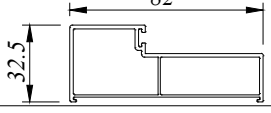
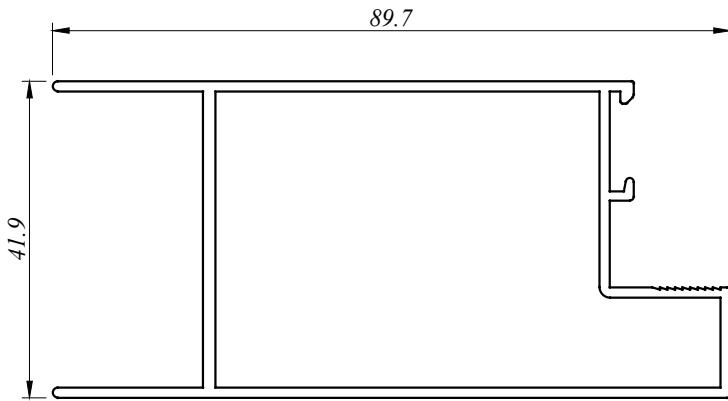

SWD 4601
1.070 Kg/M
AP : 322.414 MM

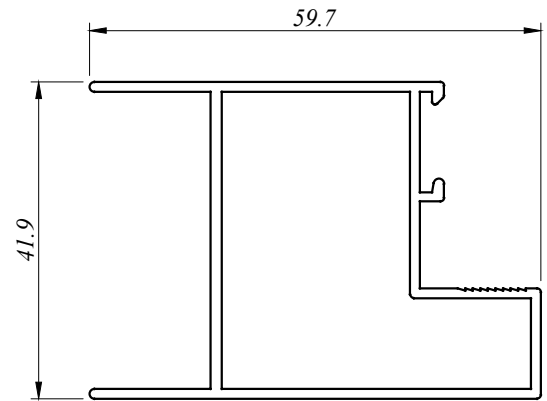

SWD 4602
0.841 Kg/M
AP : 254.527 MM

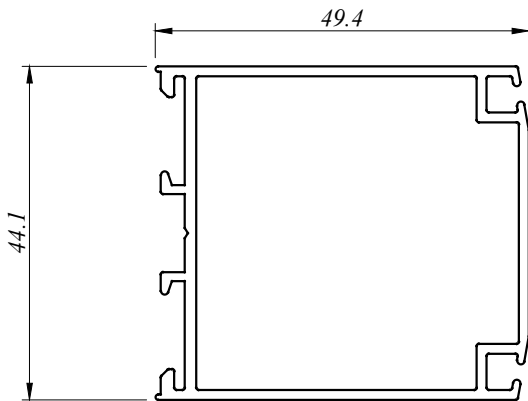

SWD 4603
0.763 Kg/M
AP : 246.091 MM

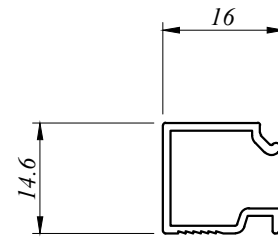

SWD 4604
0.139 Kg/M
AP : 102.628 MM

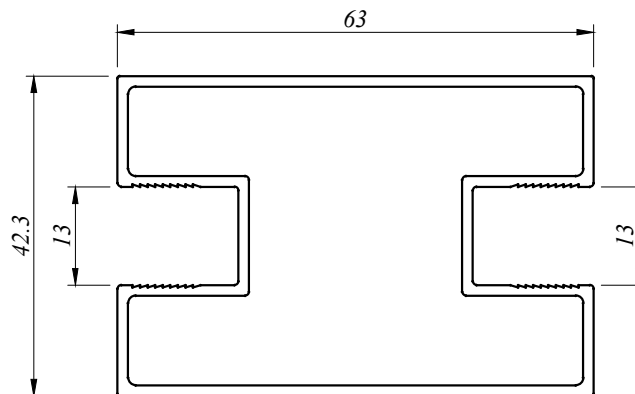

SWD 4605
1.047 Kg/M
AP : 284.753 MM

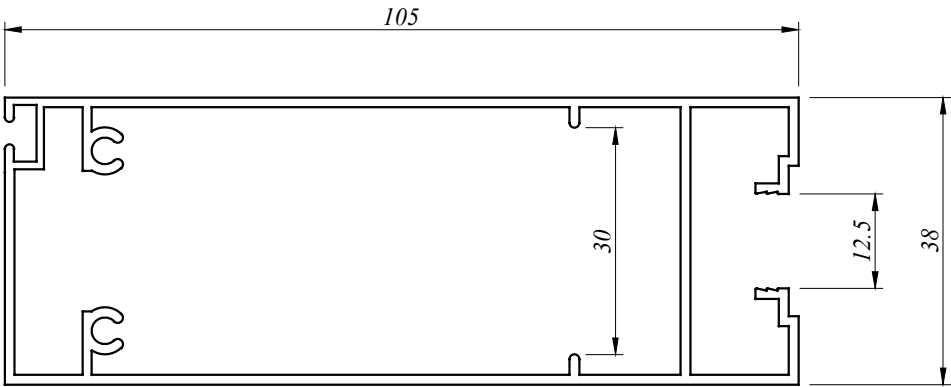

SWD 4608
1.292 Kg/M
AP : 395.424 MM

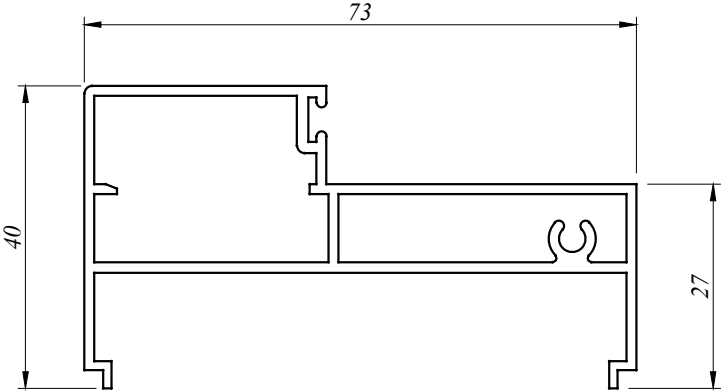

SWD 4609
0.952 Kg/M
AP : 274.455 MM

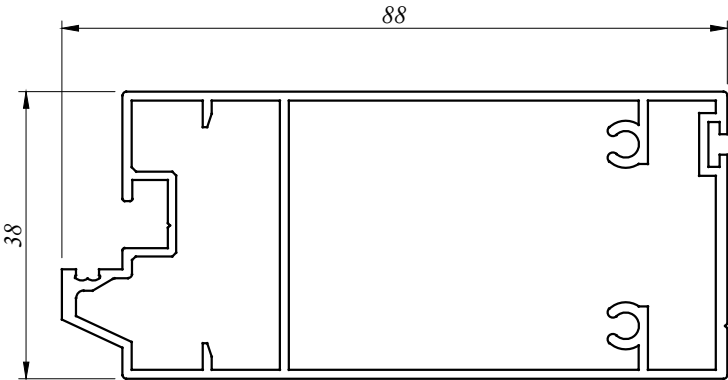

SWD 4610
1.187 Kg/M
AP : 280.360 MM

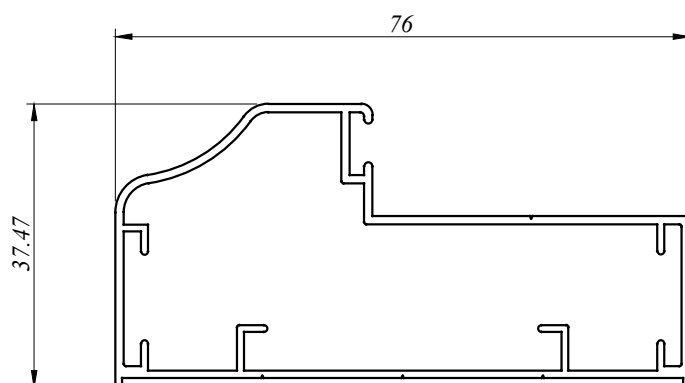

SWD 4611
0.750 Kg/M
AP : 232.227 MM

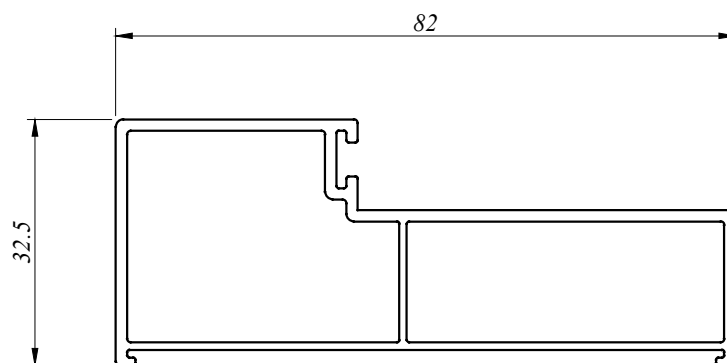

SWD 4612
0.897 Kg/M
AP : 245.638 MM

aluminium profiles component usage

Swing Door - SWD 460 Series

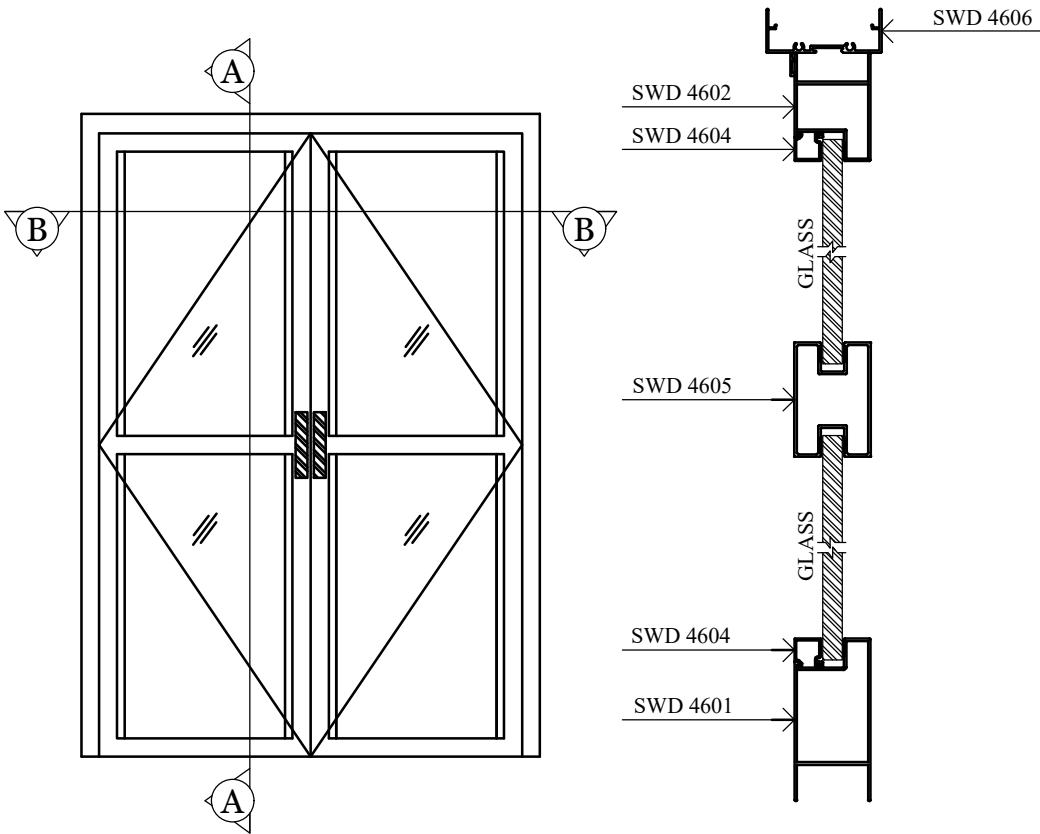

SECTION VIEW A - A

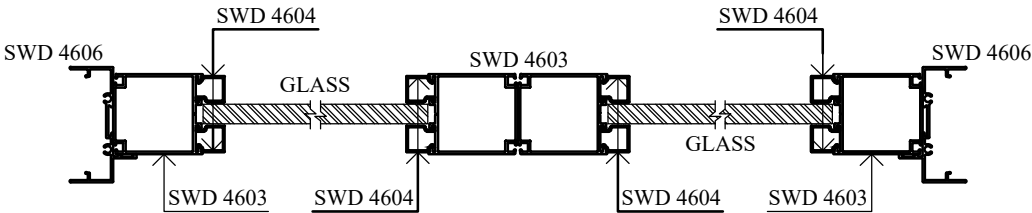

SECTION VIEW B - B

we made aluminium into shapes ...

profile information

aluminium profiles component usage

Swing Door - SWD 460 Series

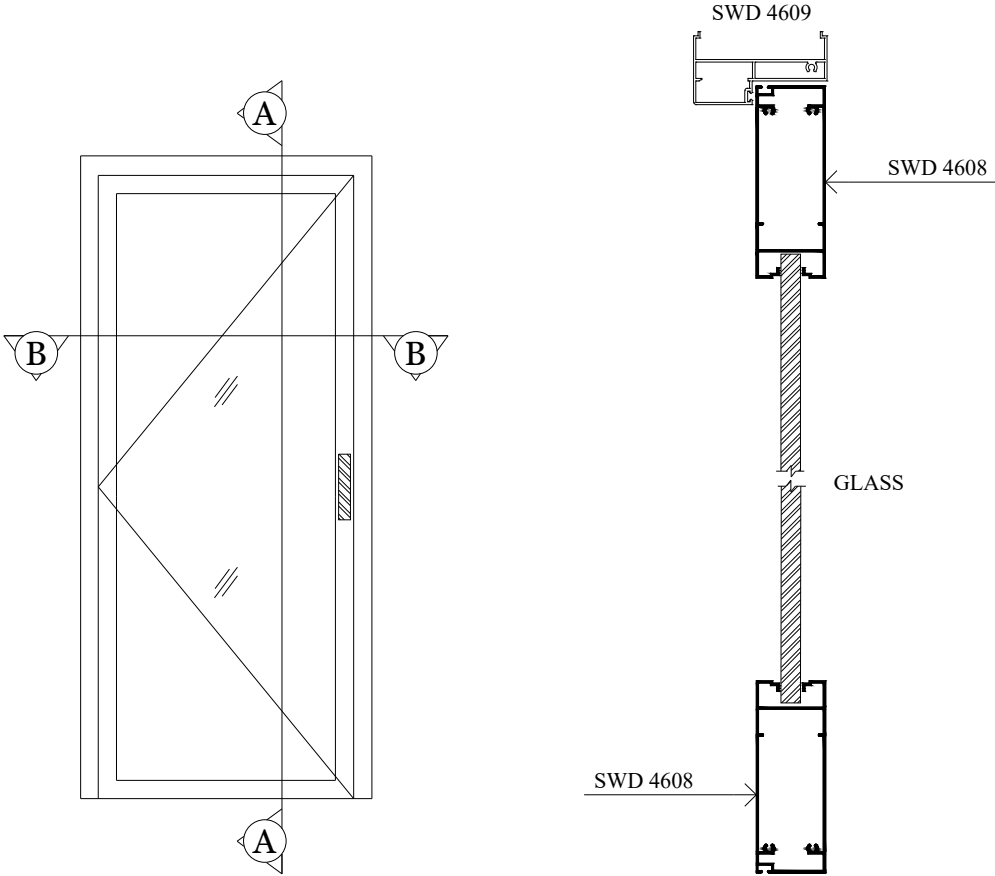

SECTION VIEW A - A

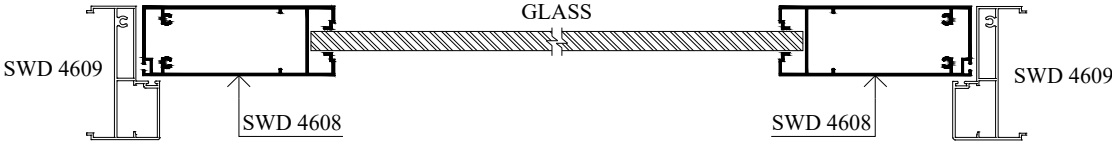

SECTION VIEW B - B



BP Aluminium Extrusion Sdn. Bhd.

**No.15 & 16, 1C KKIP Selatan, Industrial Zone 2, KKIP,
88450, Jalan Sepanggar, Menggatal.**

t : 60-88-499333, 499111 f : 60-88-499222

b_p_a_e@yahoo.com