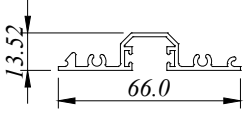
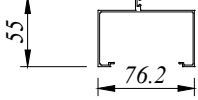
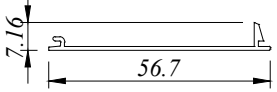

*SF - Shop Front*  
*62 SERIES*

PROFILE NO.	PICTURE OF PROFILE	WEIGHT (KG/M)	THICKNESS	PACKING IN BUNDLE (PCS)
			AREA PERIMETER	
SF 6201		0.743	1.10 MM 454.253 MM	4
SF 6203		0.653	1.10 MM 405.857 MM	4
SF 6206		0.264	1.00 MM 156.336 MM	20
SF 6207		0.340	1.10 MM 198.224 MM	10
SF 6208		1.076	1.25 MM 318.188 MM	3
SF 6209		0.965	1.25 MM 279.401 MM	3
SF 6210		0.380	2.15 MM 129.480 MM	10
SF 6211		1.565	1.50 MM 381.688 MM	2
SF 6212		1.378	1.40 MM 354.286 MM	3
SF 6213		1.045	1.40 MM 515.49 MM	4
SF 6214		0.268	1.00 MM 183.95 MM	20
SF 6215		1.550	1.40 MM 415.371 MM	3
SF 6216		1.156	1.40 MM 580.10 MM	4

All Profiles are standard length 6.1 M for SF Series

PROFILE NO.	PICTURE OF PROFILE	WEIGHT (KG/M)	THICKNESS	PACKING IN BUNDLE (PCS)
			AREA PERIMETER	
SF 6217		0.534	1.40 MM 254.06 MM	10
SF 6218		0.720	1.20 MM 409.837 MM	4
SF 6219		0.195	1.00 MM 135.992 MM	20

All Profiles are standard length 6.1 M for SF Series

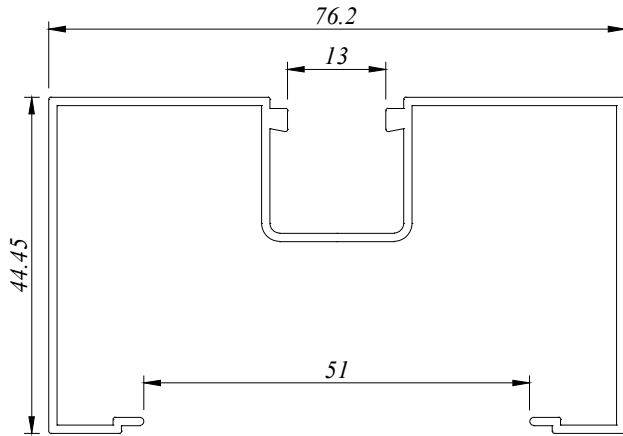

SF 6201  
0.743 Kg/M  
AP : 454.253 MM

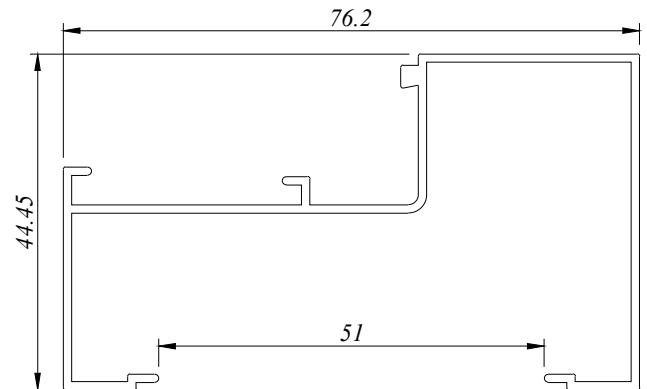

SF 6203  
0.653 Kg/M  
AP : 405.857 MM

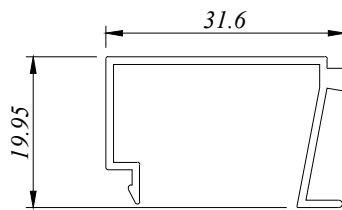

SF 6206  
0.264 Kg/M  
AP : 156.336 MM

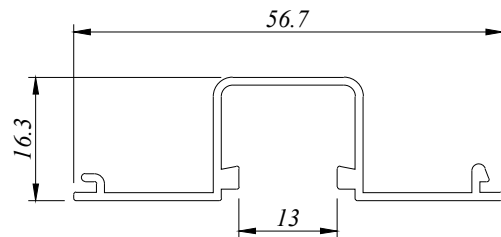

SF 6207  
0.340 Kg/M  
AP : 198.224 MM

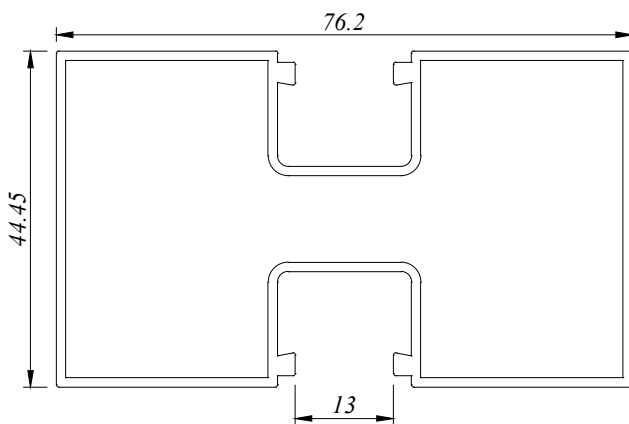

SF 6208  
1.076 Kg/M  
AP : 318.188 MM

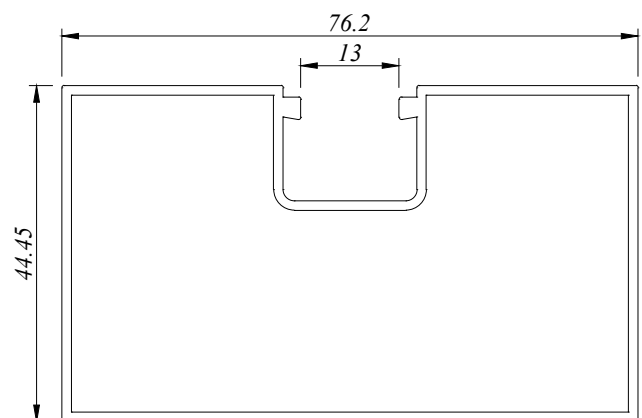

SF 6209  
0.965 Kg/M  
AP : 279.401 MM

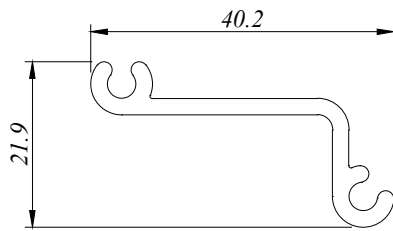

SF 6210  
0.380 Kg/M  
AP : 129.480 MM

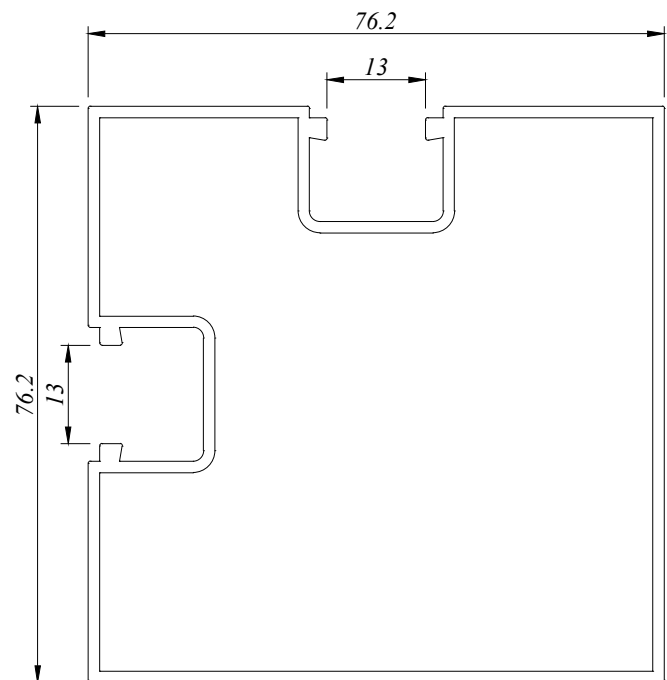

SF 6211  
1.565 Kg/M  
AP : 381.688 MM

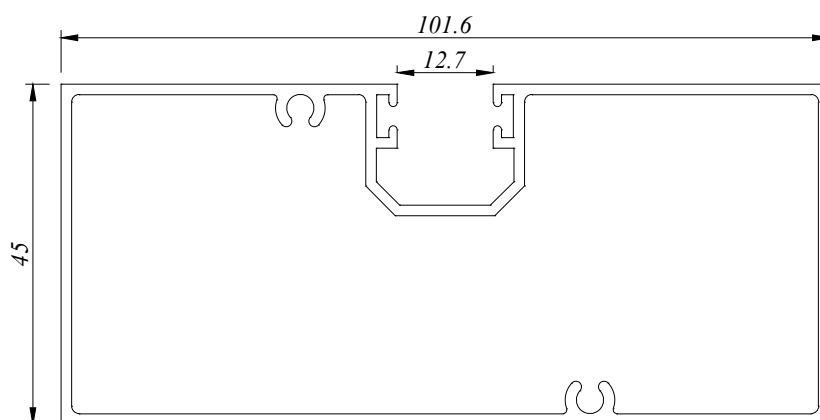

SF 6212  
1.378 Kg/M  
AP : 354.286 MM

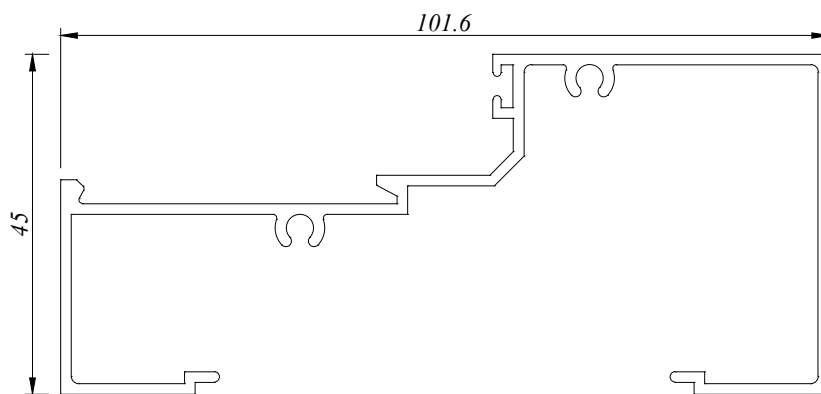

SF 6213  
1.045 Kg/M  
AP : 515.49 MM

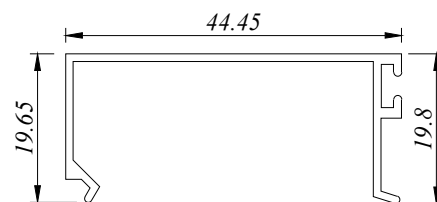

SF 6214  
0.268 Kg/M  
AP : 183.95 MM

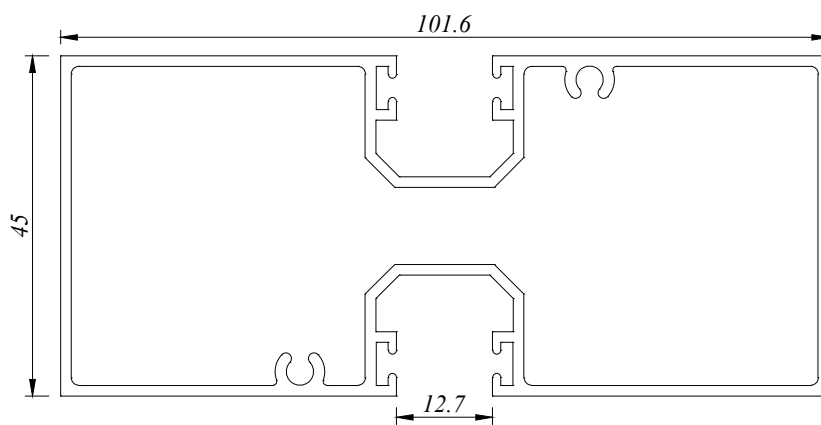

SF 6215  
1.550 Kg/M  
AP : 415.371 MM

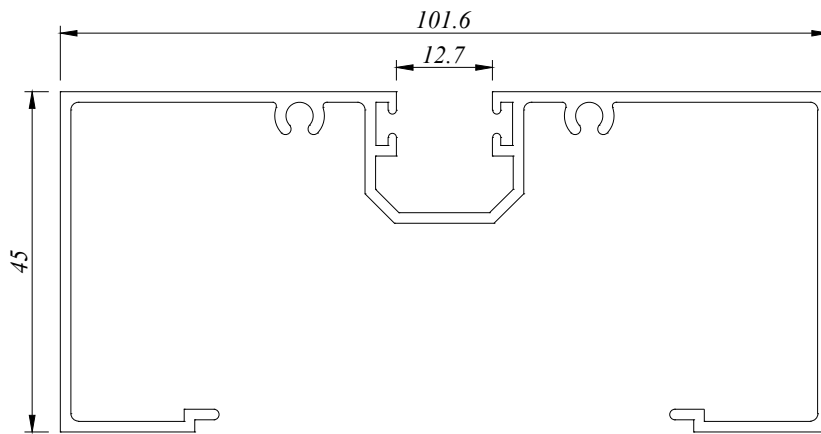

SF 6216  
1.156 Kg/M  
AP : 580.10 MM

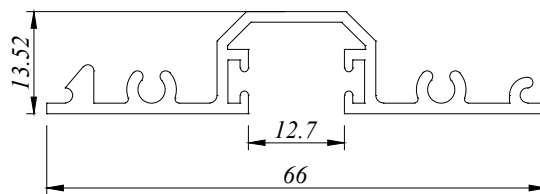

SF 6217  
0.534 Kg/M  
AP : 254.06 MM

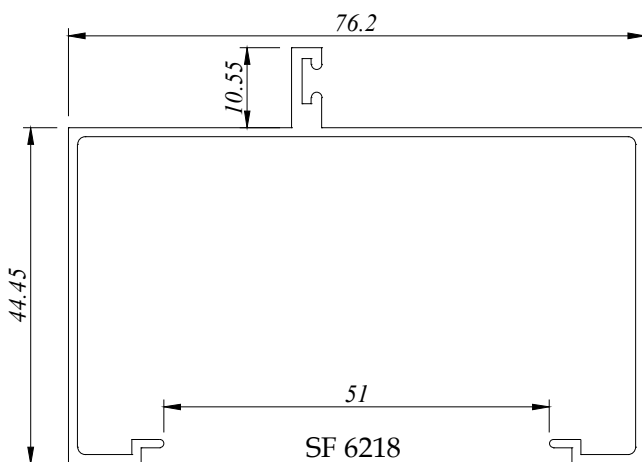

SF 6218  
0.720 Kg/M  
AP : 409.837 MM

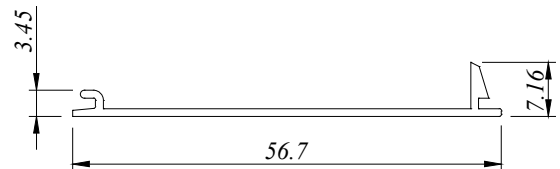

SF 6219  
0.195 Kg/M  
AP : 135.992 MM

# aluminium profiles component usage

## Shop Front - SF 62 Series

ASSEMBLY DRAWING

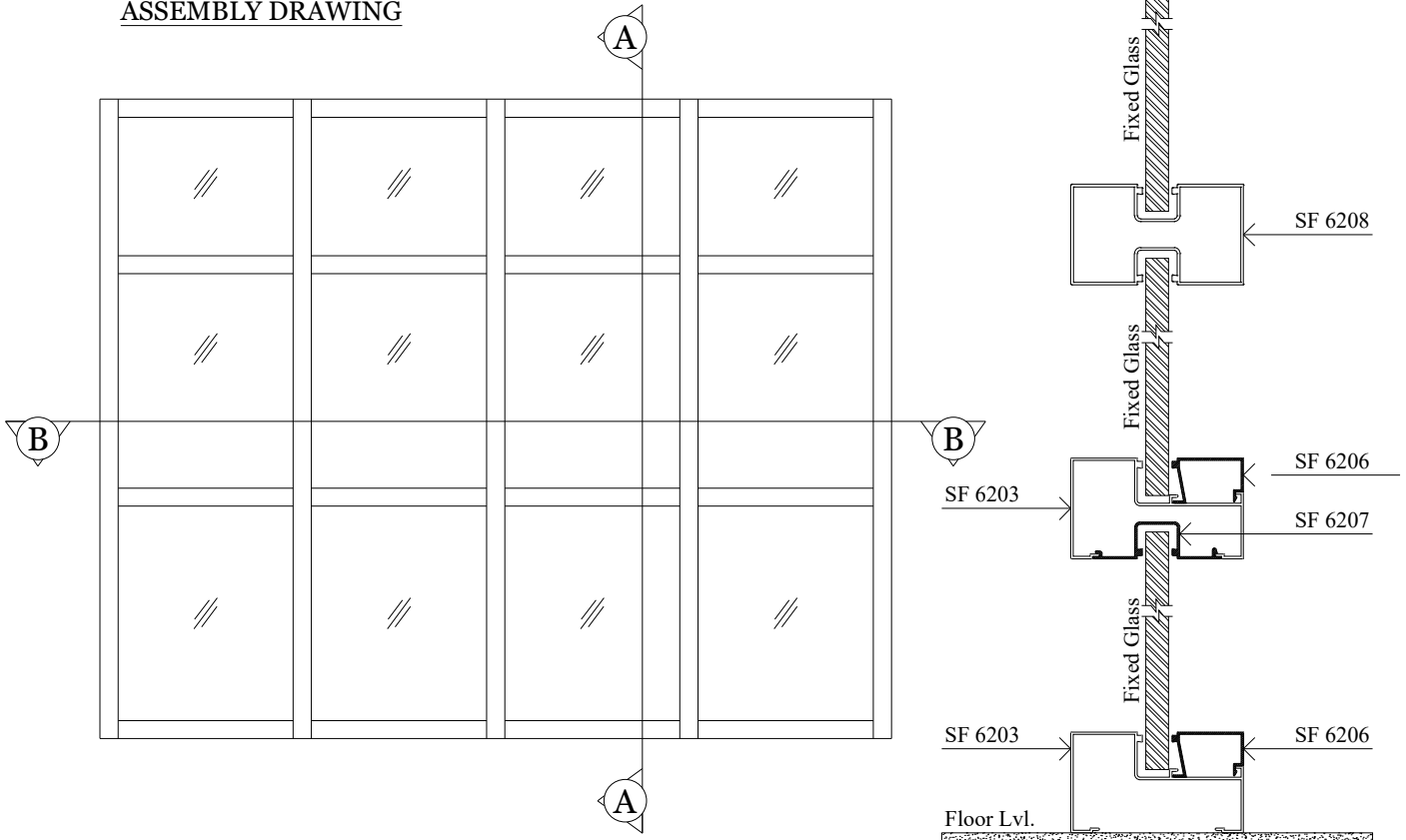

SECTION VIEW A - A

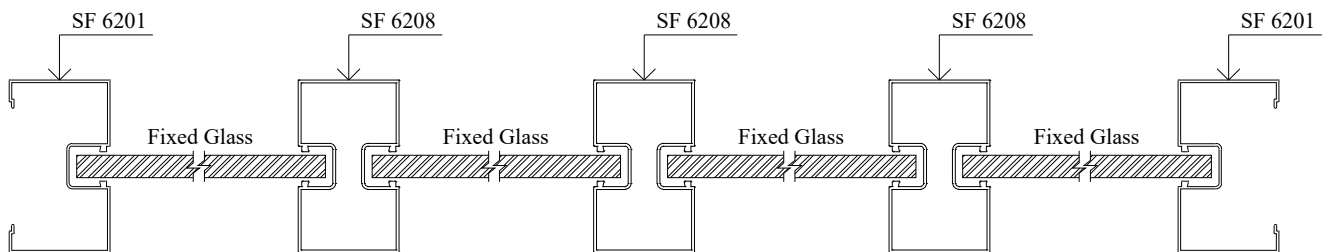

SECTION VIEW B - B



**BP Aluminium Extrusion Sdn. Bhd.**

No.15 & 16, 1C KKIP Selatan, Industrial Zone 2, KKIP,  
88450, Jalan Sepanggar, Menggatal.

t : 60-88-499333, 499111 f : 60-88-499222

b\_p\_a\_e@yahoo.com