

SF - Shop Front
612 SERIES

PROFILE NO.	PICTURE OF PROFILE	WEIGHT (KG/M)	THICKNESS	PACKING IN BUNDLE (PCS)
			AREA PERIMETER	
SF 6121		0.705	1.20 MM 418.464 MM	6
SF 6122		0.996	1.20 MM 316.976 MM	4
SF 6124		0.827	1.20 MM 318.867 MM	4
SF 6125		0.253	1.20 MM 159.482 MM	20

All Profiles are standard length 6.1 M for SF Series

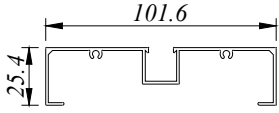
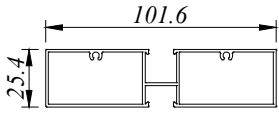
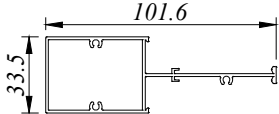
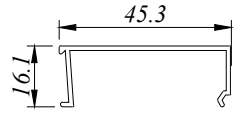
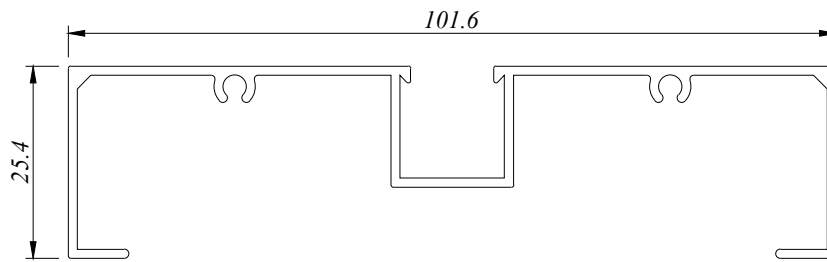

SF 6121
0.705 Kg/M
AP : 418.464 MM

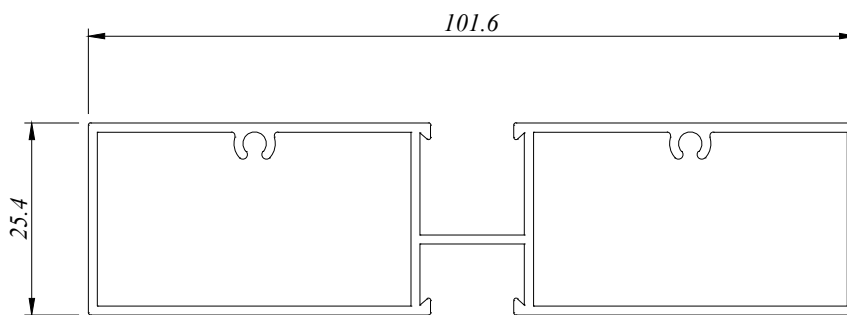

SF 6122
0.996 Kg/M
AP : 316.976 MM

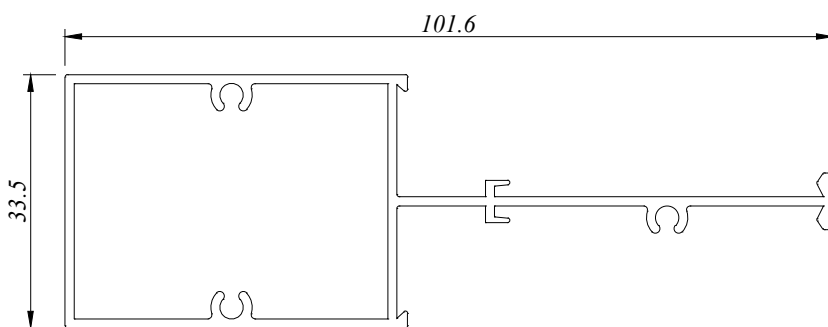

SF 6124
0.827 Kg/M
AP : 318.867 MM

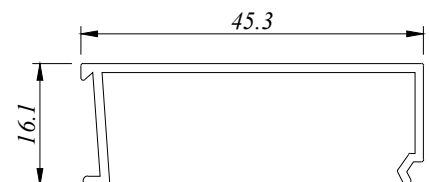

SF 6125
0.253 Kg/M
AP : 159.482 MM

aluminium profiles component usage

Shop Front - SF 612 Series

ASSEMBLY DRAWING

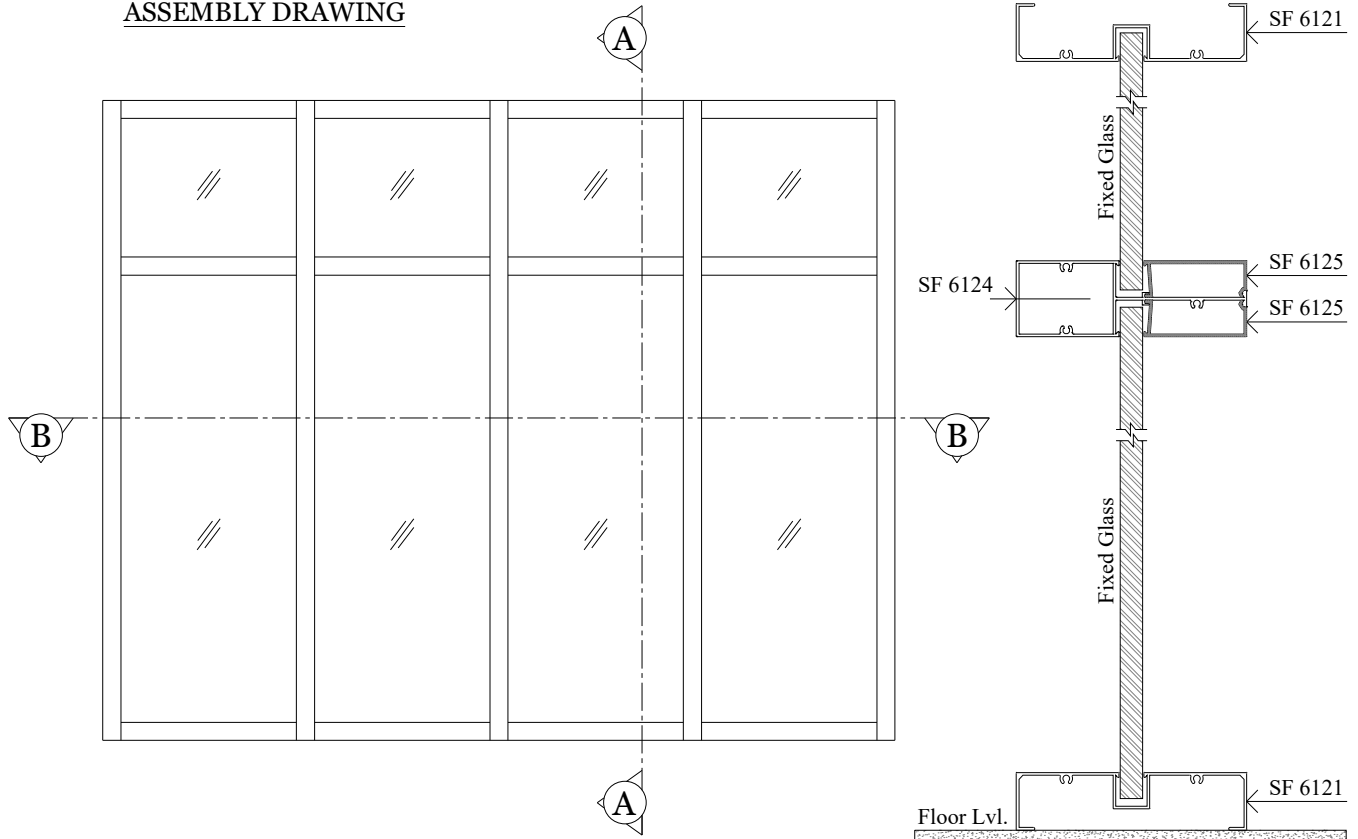

SECTION VIEW A - A

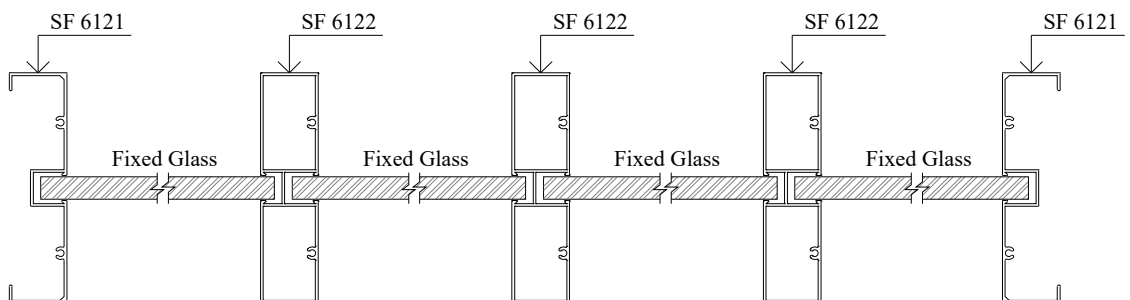

SECTION VIEW B - B



BP Aluminium Extrusion Sdn. Bhd.

**No.15 & 16, 1C KKIP Selatan, Industrial Zone 2, KKIP,
88450, Jalan Sepanggar, Menggatal.**

t : 60-88-499333, 499111 f : 60-88-499222

b_p_a_e@yahoo.com