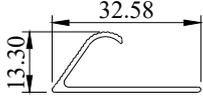
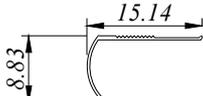
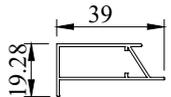
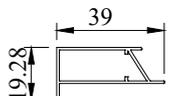
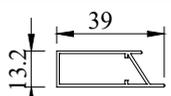
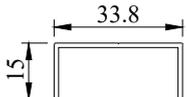
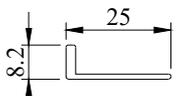
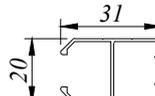
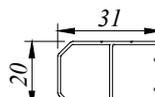
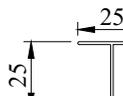
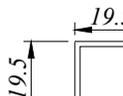
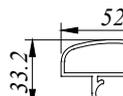
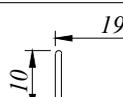
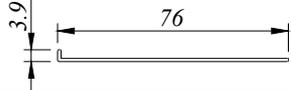
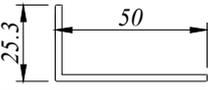
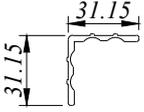
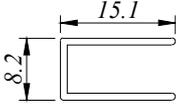
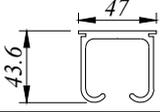
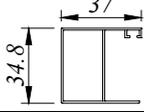
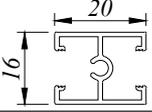
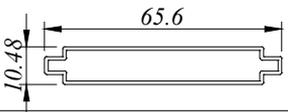
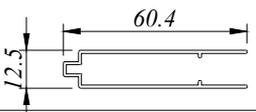
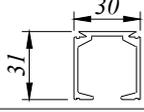
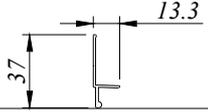
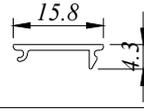
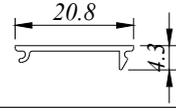

*MISC - Miscellaneous*

*51 SERIES*

PROFILE NO.	PICTURE OF PROFILE	WEIGHT (KG/M)	THICKNESS	PACKING IN BUNDLE (PCS)
			AREA PERIMETER	
MISC 5102		0.178	1.10 MM 107.058 MM	20
MISC 5103		0.244	1.00 MM 158.688 MM	10
MISC 5108		0.306	1.00 MM 118.659 MM	12
MISC 5108 H		0.342	1.20 MM 118.840 MM	12
MISC 5109		0.322	1.20 MM 106.94 MM	12
MISC 5113		0.199	1.20 MM 124.250 MM	20
MISC 5114		0.124	1.20 MM 65.327 MM	20
MISC 5115		0.242	0.90 MM 195.212 MM	12
MISC 5116		0.261	0.90 MM 149.715 MM	12
MISC 5118		0.140	1.00 MM 96.712 MM	20
MISC 5119		0.218	1.40 MM 119.814 MM	40
MISC 5120		0.850	1.70 MM 235.943 MM	4
MISC 5121		0.075	1.00 MM 57.142 MM	20

All Profiles are standard length 6.1 M for MISC Series

PROFILE NO.	PICTURE OF PROFILE	WEIGHT (KG/M)	THICKNESS	PACKING IN BUNDLE (PCS)
			AREA PERIMETER	
MISC 5122		0.235	1.10 MM 159.156 MM	10
MISC 5123		0.455	2.30 MM 149.956 MM	5
MISC 5124		0.335	2.70 MM 125.871 MM	10
MISC 5125		0.089	0.90 MM 73.970 MM	20
MISC 5126		1.327	2.80 MM 301.364 MM	2
MISC 5127		0.362	0.90 MM 193.397 MM	6
MISC 5129		0.207	1.00 MM 156.916 MM	20
MISC 5132		0.400	1.00 MM 150.443 MM	6
MISC 5133		0.360	1.00 MM 266.682 MM	8
MISC 5134		0.558	1.80 MM 210.517 MM	6
MISC 5135		0.178	1.20 MM 101.938 MM	10
MISC 5136		0.057	1.00 MM 43.775 MM	20
MISC 5137		0.070	1.00 MM 53.775 MM	20

All Profiles are standard length 6.1 M for MISC Series

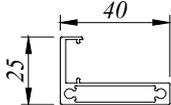
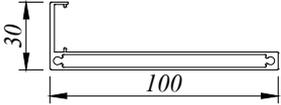
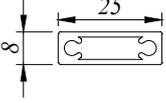
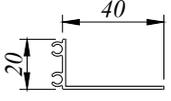
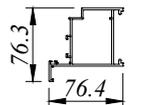
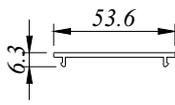
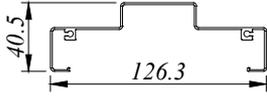
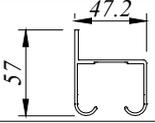
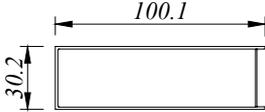
PROFILE NO.	PICTURE OF PROFILE	WEIGHT (KG/M)	THICKNESS	PACKING IN BUNDLE (PCS)
			AREA PERIMETER	
MISC 5138		0.450	1.00 MM 233.805 MM	5
MISC 5139		0.899	1.20 MM 483.310 MM	5
MISC 5140		0.270	1.30 MM 124.509 MM	5
MISC 5141		0.268	1.30 MM 150.098 MM	10
MISC 5142		0.340	1.40 MM 181.370 MM	5
MISC 5143		1.589	2.00 MM 399.262 MM	6
MISC 5144		0.316	2.00 MM 128.579 MM	20
MISC 5145		0.801	1.10 MM 491.538 MM	3
MISC 5146		0.825	1.65 MM 323.966 MM	4
MISC 5147		0.817	1.20 MM 267.950 MM	3

All Profiles are standard length 6.1 M for MISC Series

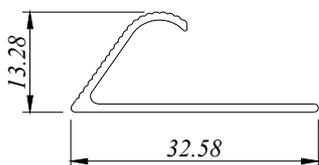

MISC 5102  
0.178 Kg/M  
AP : 107.058 MM

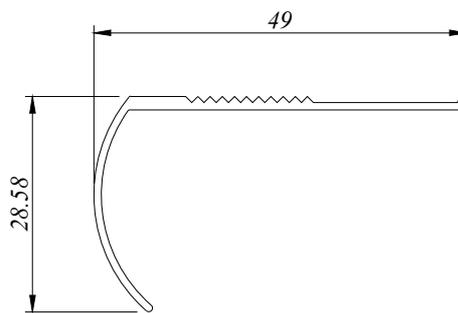

MISC 5103  
0.244 Kg/M  
AP : 158.688 MM

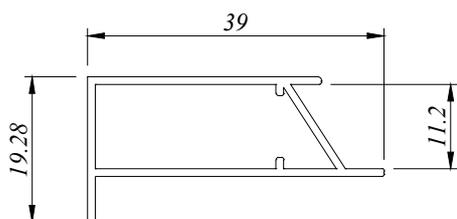

MISC 5108  
0.306 Kg/M  
AP : 118.659 MM

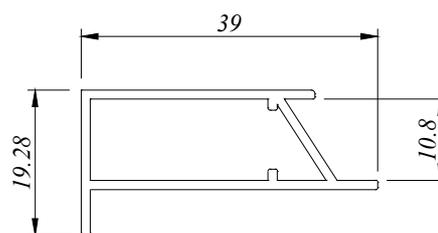

MISC 5108 H  
0.342 Kg/M  
AP : 118.840 MM

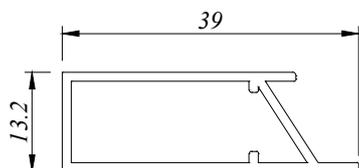

MISC 5109  
0.322 Kg/M  
AP : 106.94 MM

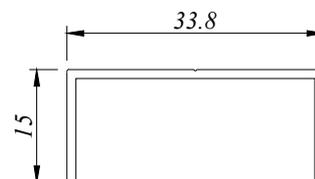

MISC 5113  
0.199 Kg/M  
AP : 124.250 MM

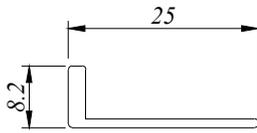

MISC 5114  
0.124 Kg/M  
AP : 65.327 MM

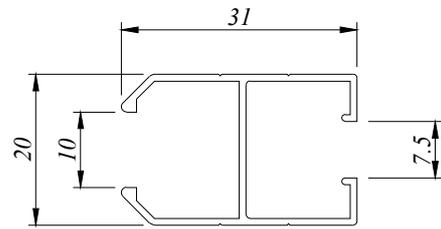

MISC 5115  
0.242 Kg/M  
AP : 195.212 MM

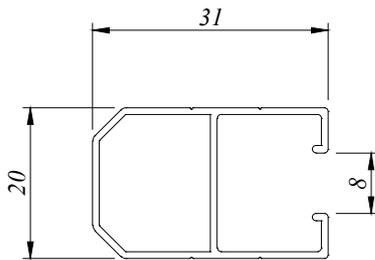

MISC 5116  
0.261 Kg/M  
AP : 149.715 MM

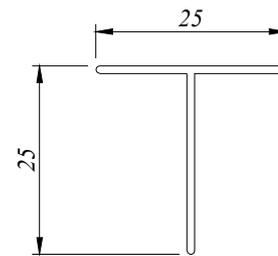

MISC 5118  
0.140 Kg/M  
AP : 96.712 MM

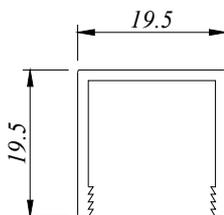

MISC 5119  
0.218 Kg/M  
AP : 119.814 MM

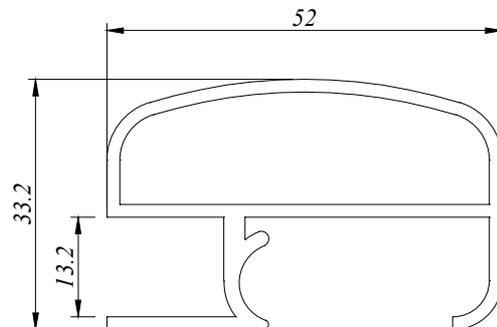

MISC 5120  
0.850 Kg/M  
AP : 235.943 MM

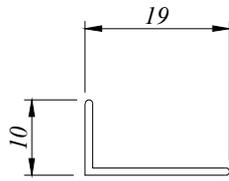

MISC 5121  
0.075 Kg/M  
AP : 57.142 MM

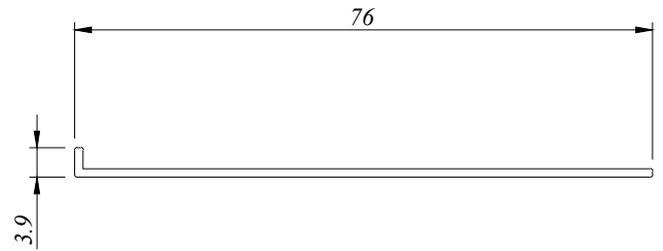

MISC 5122  
0.235 Kg/M  
AP : 159.156 MM

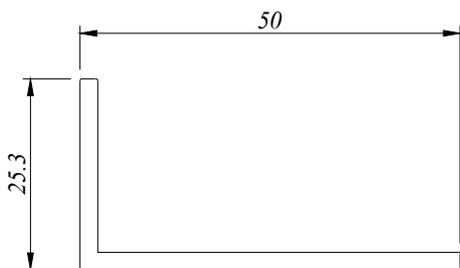

MISC 5123  
0.455 Kg/M  
AP : 149.956 MM

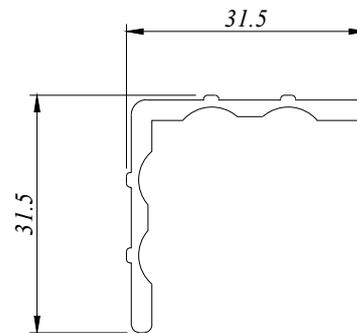

MISC 5124  
0.335 Kg/M  
AP : 125.871 MM

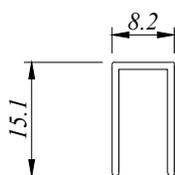

MISC 5125  
0.089 Kg/M  
AP : 73.970 MM

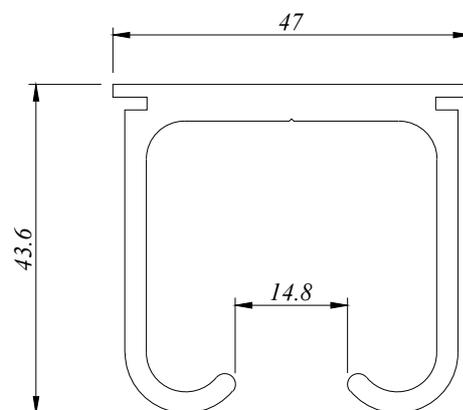

MISC 5126  
1.327 Kg/M  
AP : 301.364 MM

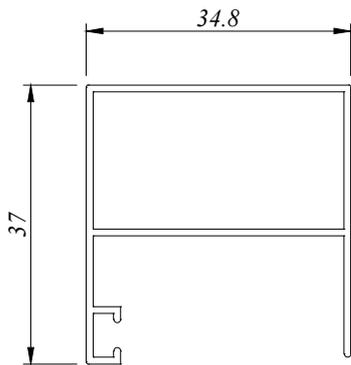

MISC 5127  
0.362 Kg/M  
AP : 193.397 MM

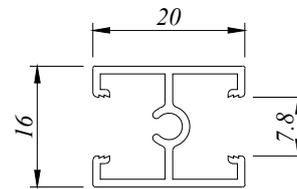

MISC 5129  
0.207 Kg/M  
AP : 156.916 MM

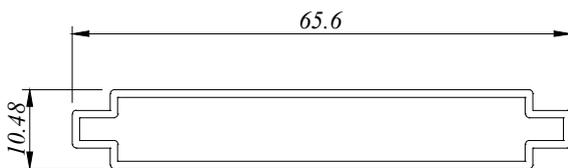

MISC 5132  
0.400 Kg/M  
AP : 150.443 MM

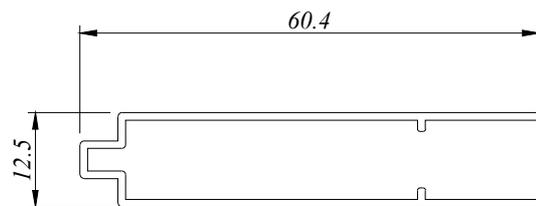

MISC 5133  
0.360 Kg/M  
AP : 266.682 MM

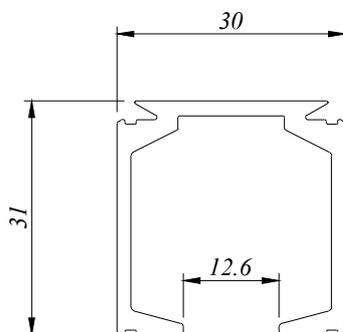

MISC 5134  
0.558 Kg/M  
AP : 210.517 MM

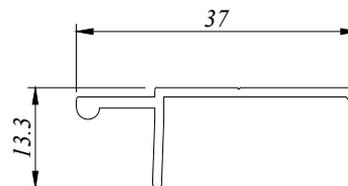

MISC 5135  
0.178 Kg/M  
AP : 101.938 MM



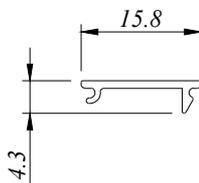

MISC 5136  
0.057 Kg/M  
AP : 43.775 MM

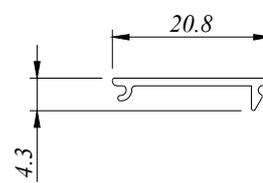

MISC 5137  
0.070 Kg/M  
AP : 53.775 MM

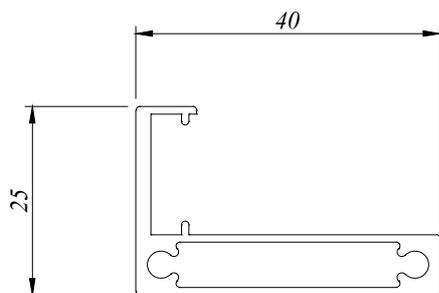

MISC 5138  
0.450 Kg/M  
AP : 233.805 MM

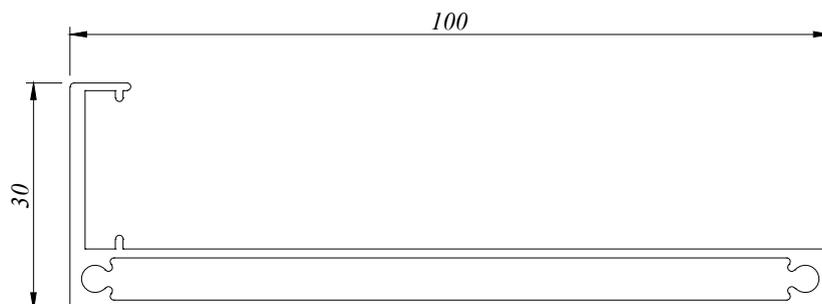

MISC 5139  
0.889 Kg/M  
AP : 483.310 MM

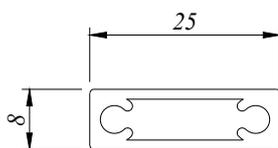

MISC 5140  
0.270 Kg/M  
AP : 124.509 MM

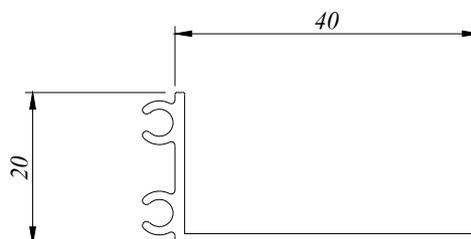

MISC 5141  
0.268 Kg/M  
AP : 150.098 MM

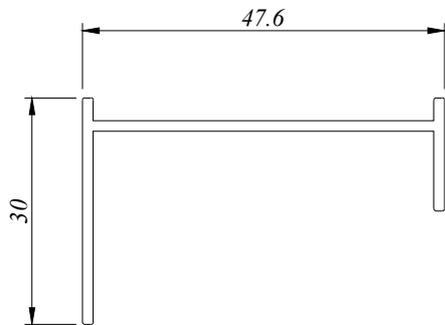

MISC 5142  
0.340 Kg/M  
AP : 181.370 MM

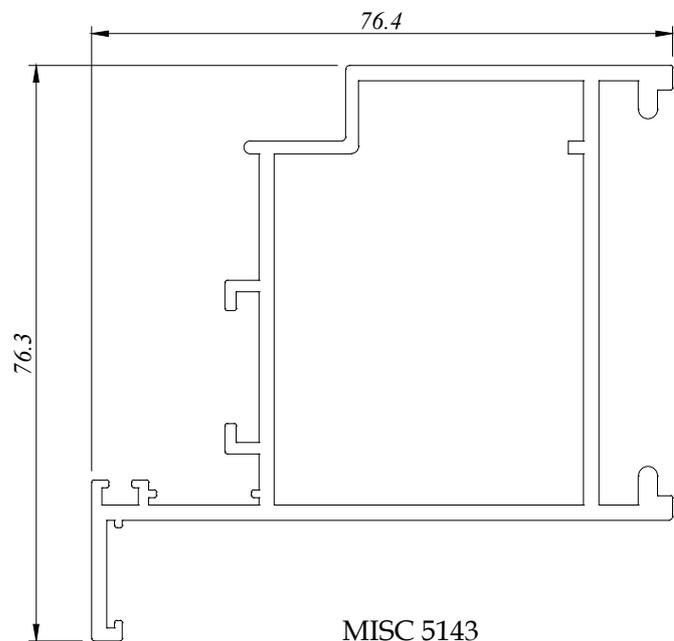

MISC 5143  
1.589 Kg/M  
AP : 399.262 MM

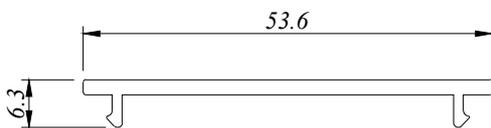

MISC 5144  
0.316 Kg/M  
AP : 128.579 MM

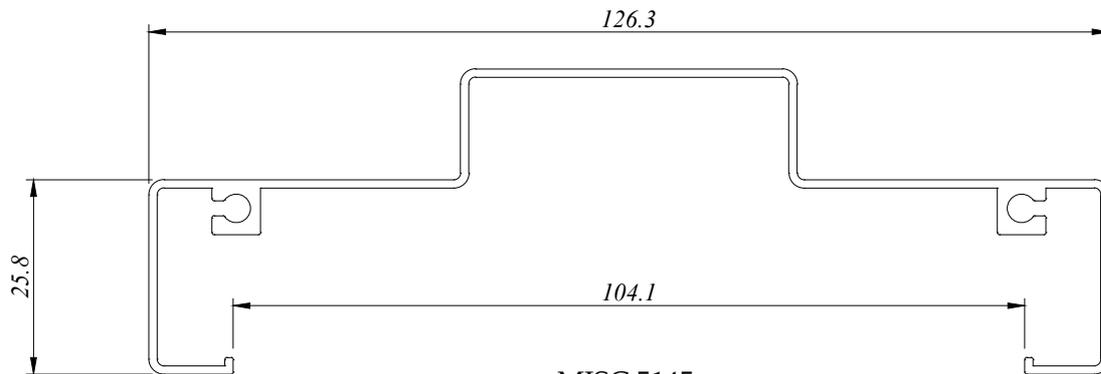

MISC 5145  
0.801 Kg/M  
AP : 491.538 MM

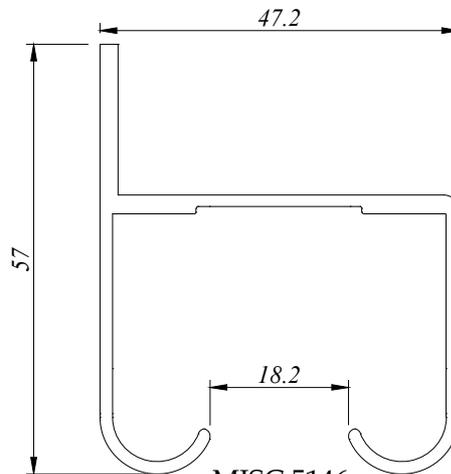

MISC 5146  
0.825 Kg/M  
AP : 323.966 MM

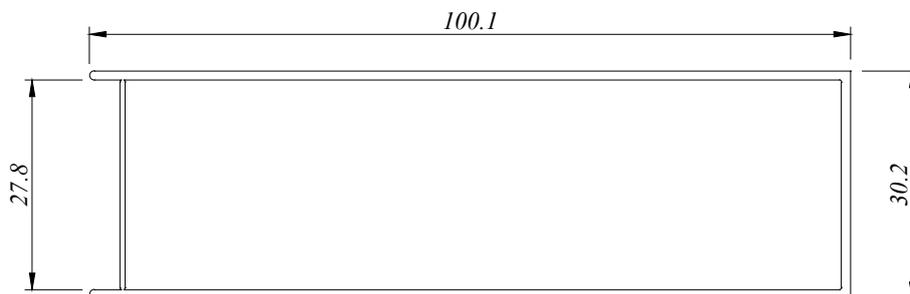

MISC 5147  
0.817 Kg/M  
AP : 267.950 MM



**BP Aluminium Extrusion Sdn. Bhd.**

No.15 & 16, 1C KKIP Selatan, Industrial Zone 2, KKIP,  
88450, Jalan Sepanggar, Menggatal.  
t : 60-88-499333, 499111 f : 60-88-499222  
b\_p\_a\_e@yahoo.com