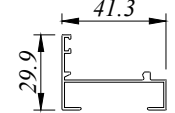
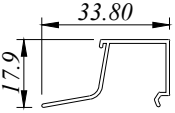
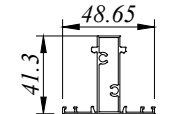
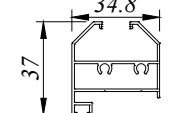
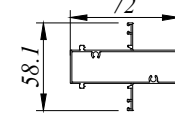
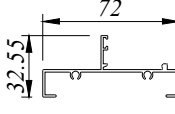
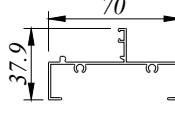
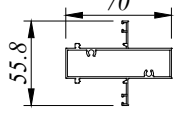
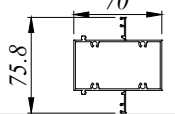
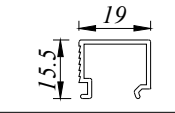
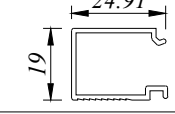
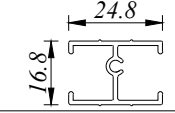
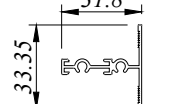

*CW - Casement Window*

*33 SERIES*

PROFILE NO.	PICTURE OF PROFILE	WEIGHT (KG/M) AREA PERIMETER (MM)				PACKING IN BUNDLE (PCS)
		( Thickness )	D 1.00 MM	H 1.20 MM	J 1.30 MM	
CW 3301		-	0.318 209.062	0.382 207.342	0.408 206.585	12
CW 3302		-	0.184 135.450	-	-	20
CW 3304		-	0.560 226.021	-	0.668 349.414	8
CW 3307		-	0.540 236.53	0.619 235.818	0.650 247.289	6
CW 3310		-	-	0.896 305.00	0.988 299.888	2
CW 3311		-	-	0.561 321.900	0.618 305.991	4
CW 3312		-	-	0.588 329.898	-	4
CW 3313		-	-	0.903 500.810	-	2
CW 3314		-	-	-	1.158 340.049	2
CW 3351		( 0.80MM ) 0.140 113.180	-	( F = 1.10MM ) 0.180 112.102	-	24
CW 3352		-	0.215 152.560	0.273 152.211	-	20
CW 3355		-	0.220 158.452	0.264 155.831	-	20
CW 3359		-	0.299 198.240	-	0.315 193.404	12

All Profiles are standard length 6.1 M for CW Series

PROFILE NO.	PICTURE OF PROFILE	WEIGHT (KG/M) AREA PERIMETER (MM)				PACKING IN BUNDLE (PCS)
		( Thickness )	D 1.00 MM	H 1.20 MM	J 1.30 MM	
CW 3364		-	0.776 261.090	-	-	2
CW 3367		(F = 1.10MM) 0.570 361.983	0.505 245.960	0.636 246.289	0.689 246.159	8
CW 3369		-	0.346 231.377	0.399 224.484	0.417 224.938	10
CW 3370		-	0.553 265.848	0.645 262.905	0.667 368.567	8
CW 3372		(1.3MM) 1.002 339.749	-	-	-	6
CW 3373		-	0.527 219.870	-	-	8
CW 3375		(0.80MM) 0.160 135.320	-	-	-	24
CW 3376		(0.95MM) 0.326 225.521	-	-	-	10
CW 3377		-	-	1.070 368.470	-	2
CW 3378		(F=1.10) 0.661 438.362	-	-	-	4
CW 3379		-	0.538 252.911	-	-	8
CW 3380 B		(B=0.85MM) 0.445 363.920	-	-	-	8
CW 3381		(0.90) 0.326 229.428	0.346 229.428	-	-	10

All Profiles are standard length 6.1 M for CW Series

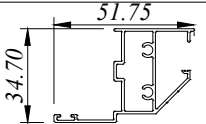
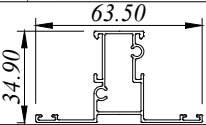
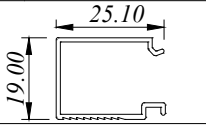
PROFILE NO.	PICTURE OF PROFILE	WEIGHT (KG/M) AREA PERIMETER (MM)				PACKING IN BUNDLE (PCS)
		Thickness	D 1.00 MM	H 1.20 MM	J 1.30 MM	
CW 3382		( 0.90 ) 0.488 245.478	0.505 245.478	-	-	8
CW 3383		-	0.553 259.166	-	-	8
CW 3384		-	0.215 153.376	-	-	20

All Profiles are standard length 6.1 M for CW Series

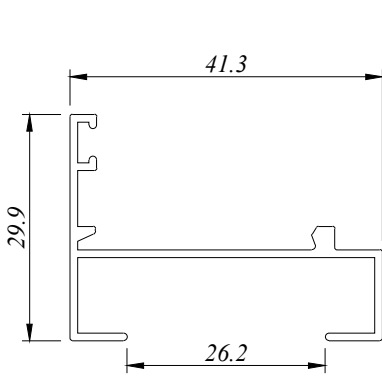

**CW 3301 D**  
0.318 Kg/M  
AP : 209.062 MM

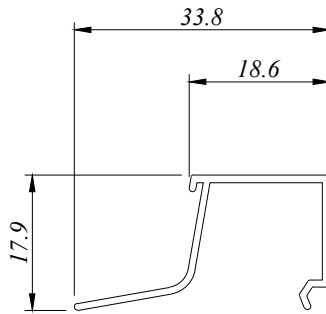

**CW 3302 D**  
0.184 Kg/M  
AP : 135.450 MM

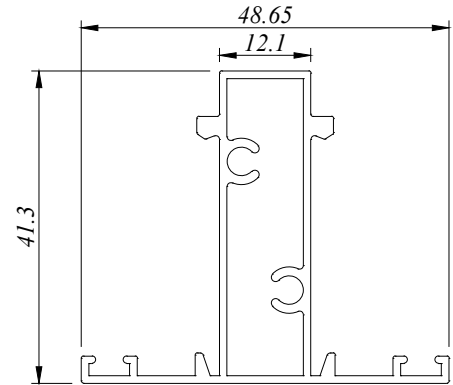

**CW 3304 D**  
0.560 Kg/M  
AP : 226.114 MM

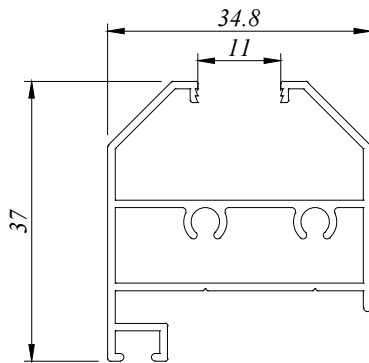

**CW 3307 D**  
0.540 Kg/M  
AP : 236.530 MM

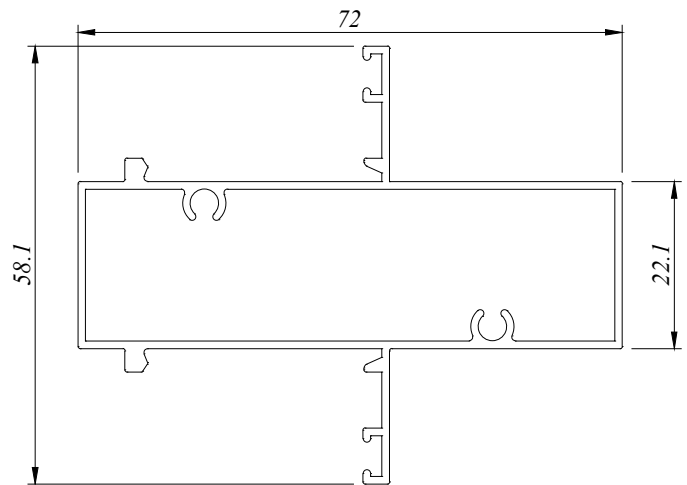

**CW 3310 H**  
0.896 Kg/M  
AP : 305.000 MM

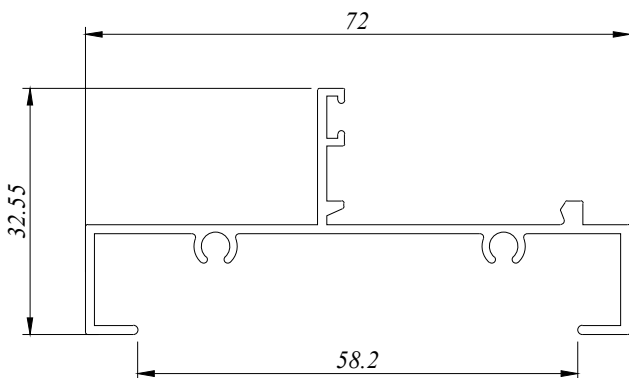

CW 3311 H  
0.561 Kg/M  
AP : 321.900 MM

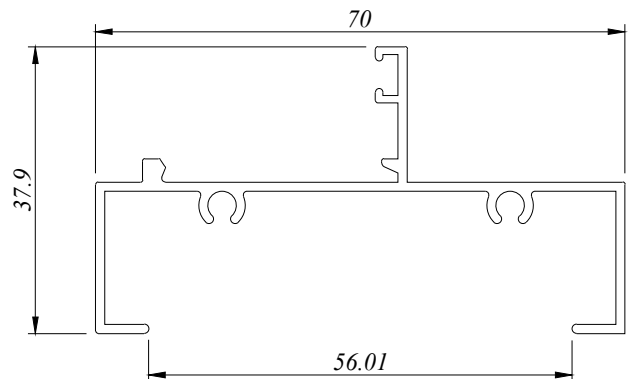

CW 3312 H  
0.588 Kg/M  
AP : 329.898 MM

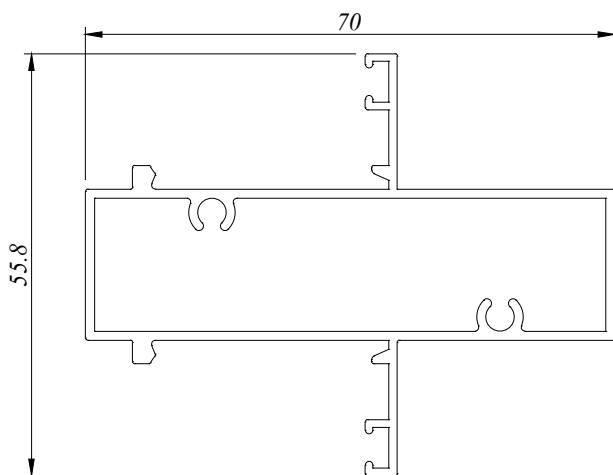

CW 3313 H  
0.903 Kg/M  
AP : 500.810 MM

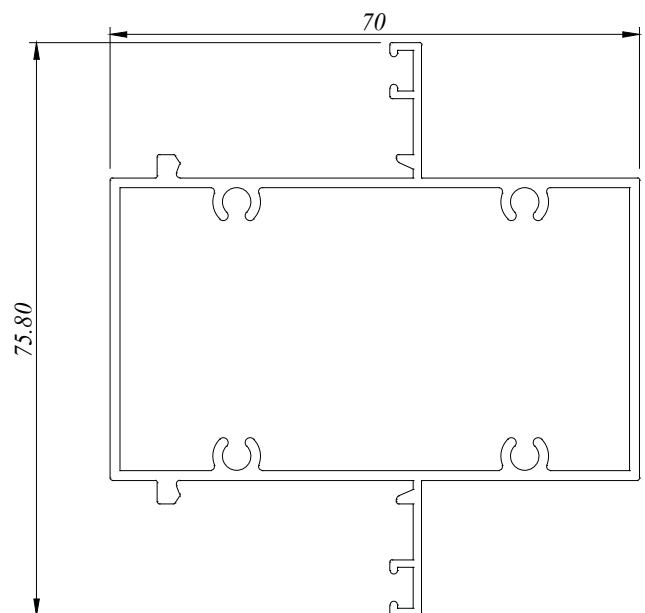

CW 3314 J  
1.158 Kg/M  
AP : 340.049 MM

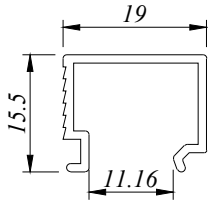

**CW 3351**  
0.140 Kg/M  
AP : 113.180 MM

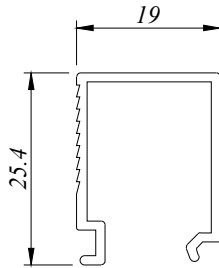

**CW 3352 D**  
0.215 Kg/M  
AP : 152.560 MM

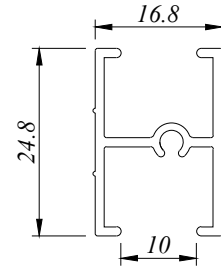

**CW 3355 D**  
0.220 Kg/M  
AP : 158.452 MM

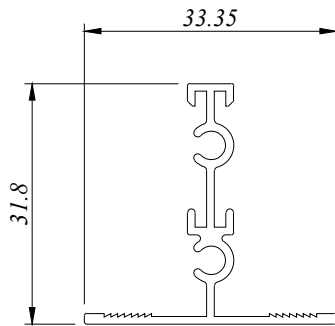

**CW 3359 D**  
0.299 Kg/M  
AP : 198.240 MM

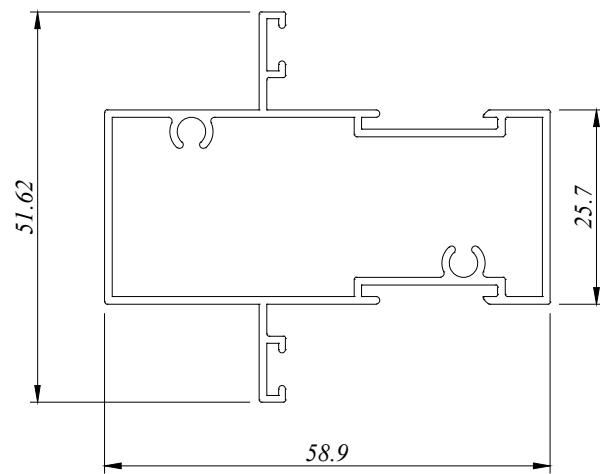

**CW 3364 D**  
0.776 Kg/M  
AP : 261.090 MM

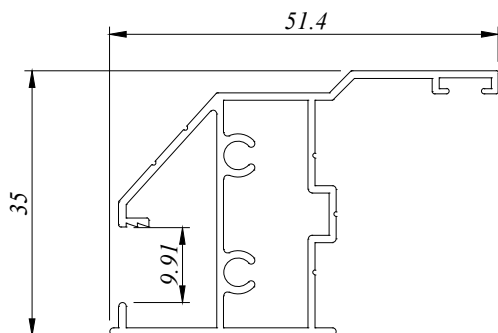

**CW 3367 D**  
0.505 Kg/M  
AP : 245.960 MM

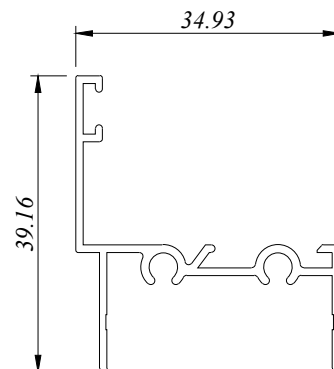

**CW 3369 D**  
0.346 Kg/M  
AP : 231.377 MM

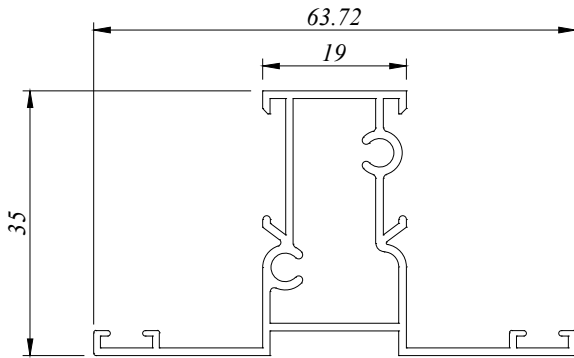

**CW 3370 D**  
0.553 Kg/M  
AP : 265.848 MM

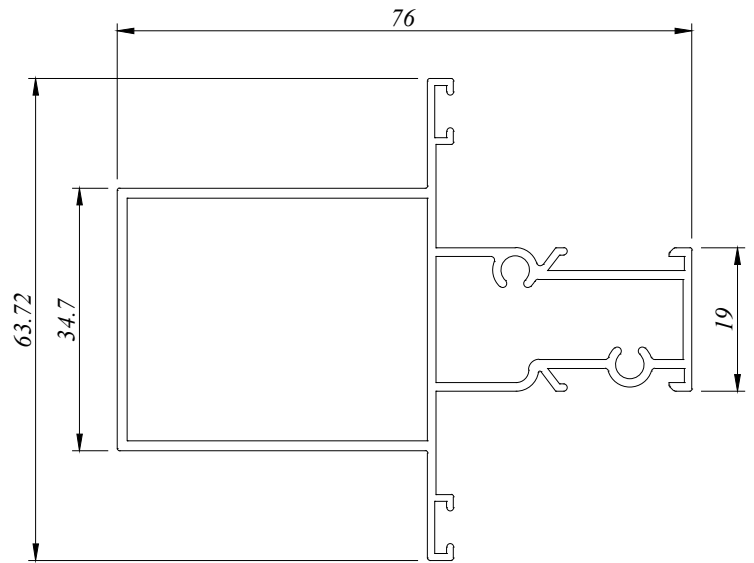

**CW 3372**  
1.002 Kg/M  
AP : 339.749 MM

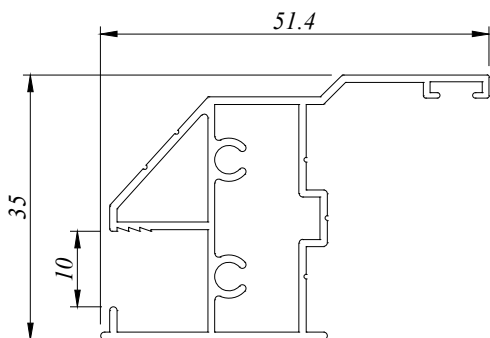

**CW 3373 D**  
0.527 Kg/M  
AP : 219.870 MM

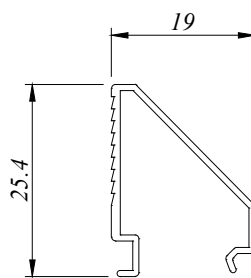

**CW 3375**  
0.160 Kg/M  
AP : 135.320 MM

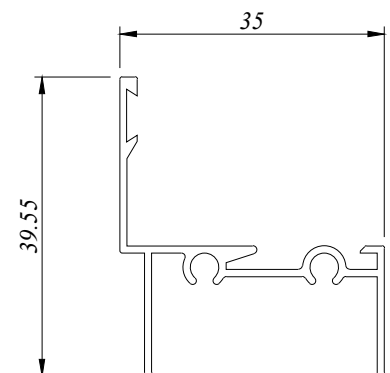

**CW 3376**  
0.326 Kg/M  
AP : 225.521 MM



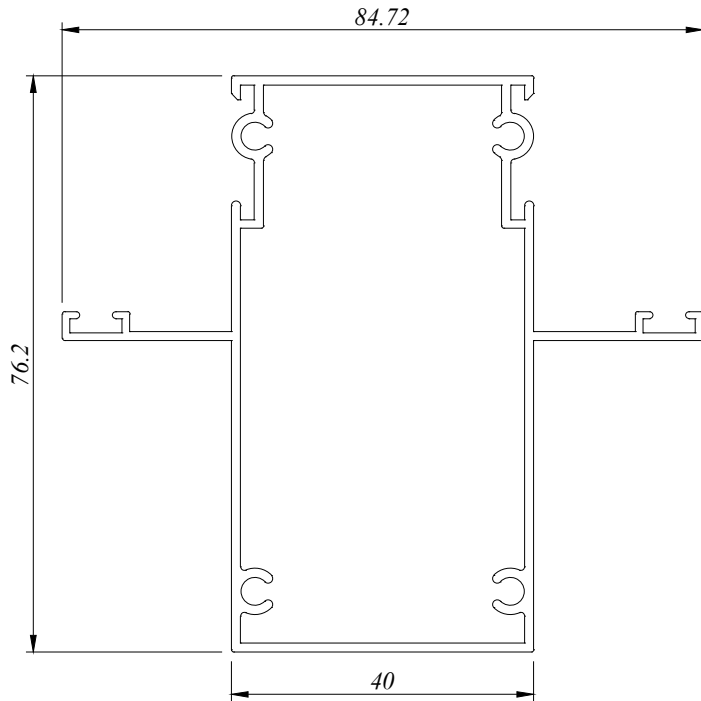

**CW 3377 H**  
1.070 Kg/M  
AP : 368.470 MM

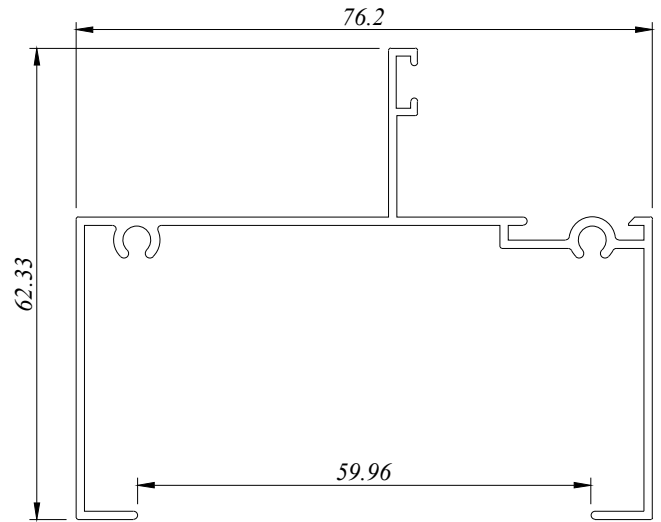

**CW 3378 F**  
0.661 Kg/M  
AP : 438.362 MM

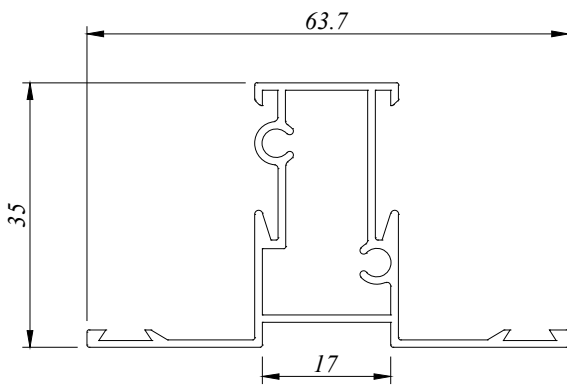

**CW 3379 D**  
0.538 Kg/M  
AP : 252.911 MM

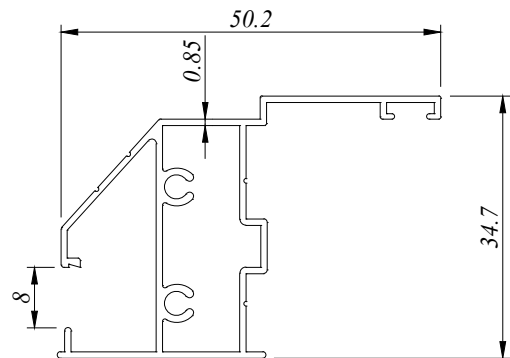

**CW 3380 B**  
0.445 Kg/M  
AP : 363.92 MM

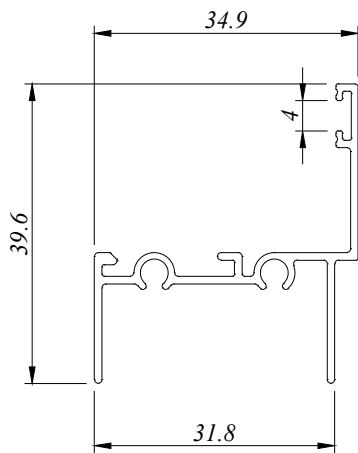

**CW 3381 D**  
0.346 Kg/M  
AP : 229.428 MM

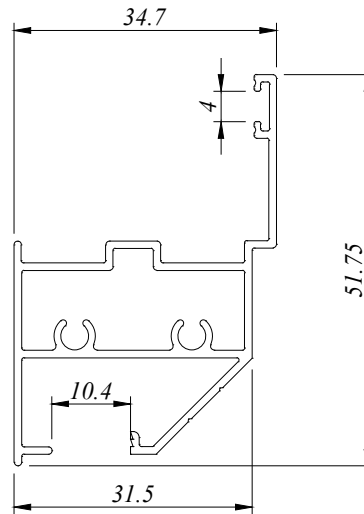

**CW 3382 D**  
0.505 Kg/M  
AP : 245.478 MM

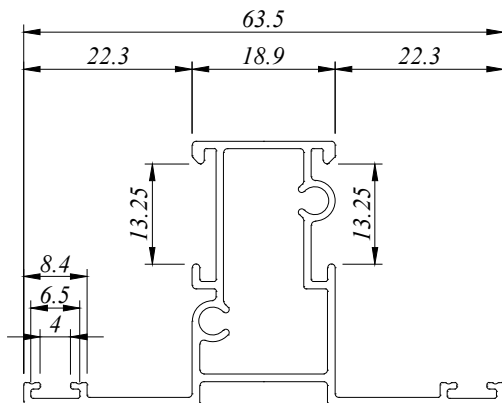

**CW 3383 D**  
0.553 Kg/M  
AP : 259.166 MM

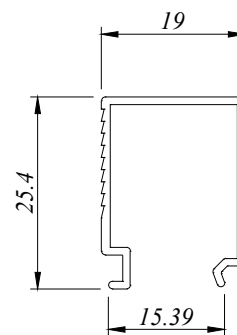

**CW 3384 D**  
0.215 Kg/M  
AP : 153.376 MM

# aluminium profiles component usage

## Casement Window - CW 33 Series

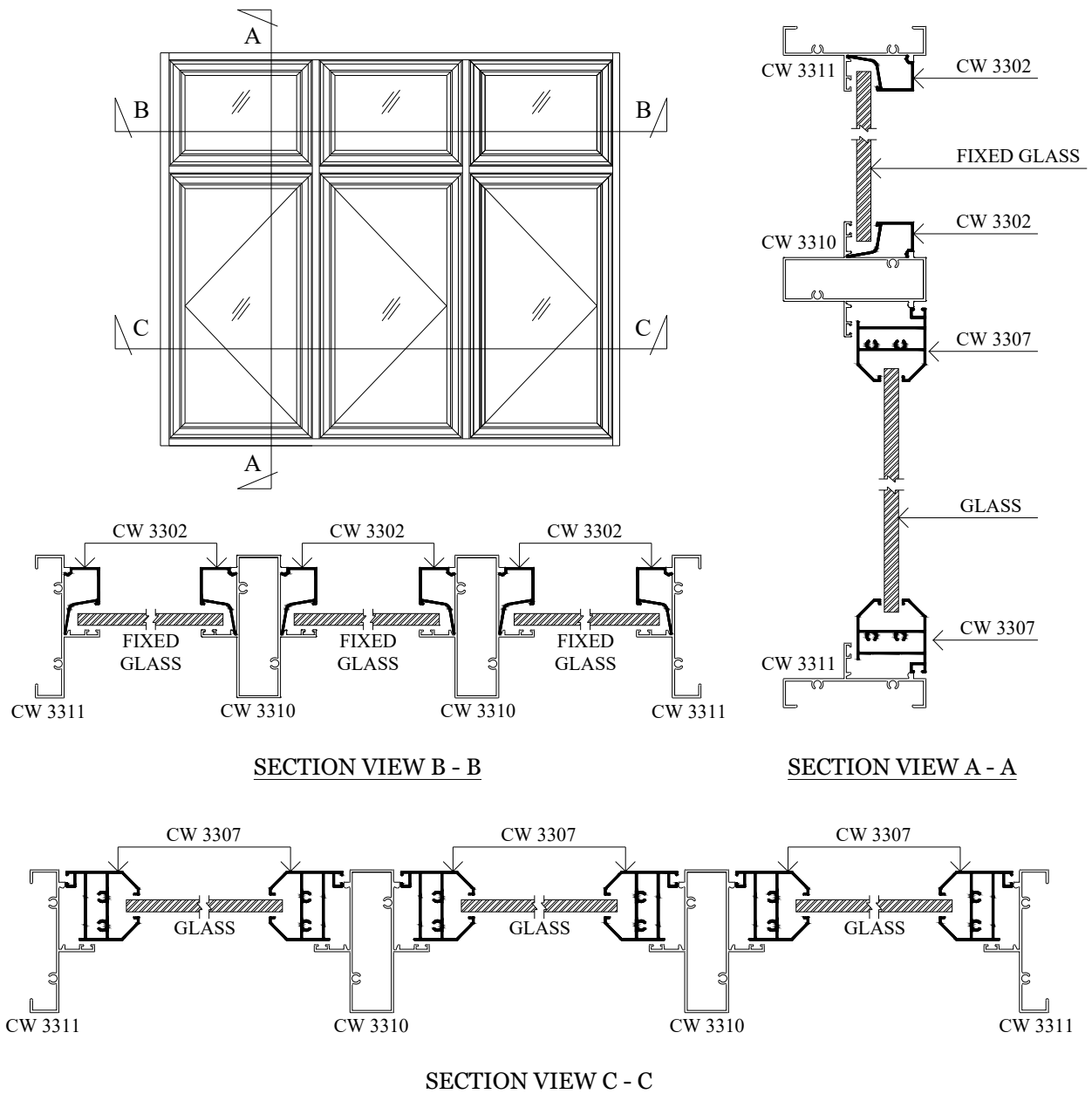

**we made aluminium into shapes ...**

*profile information*

# aluminium profiles component usage

## Casement Window - CW 33 Series

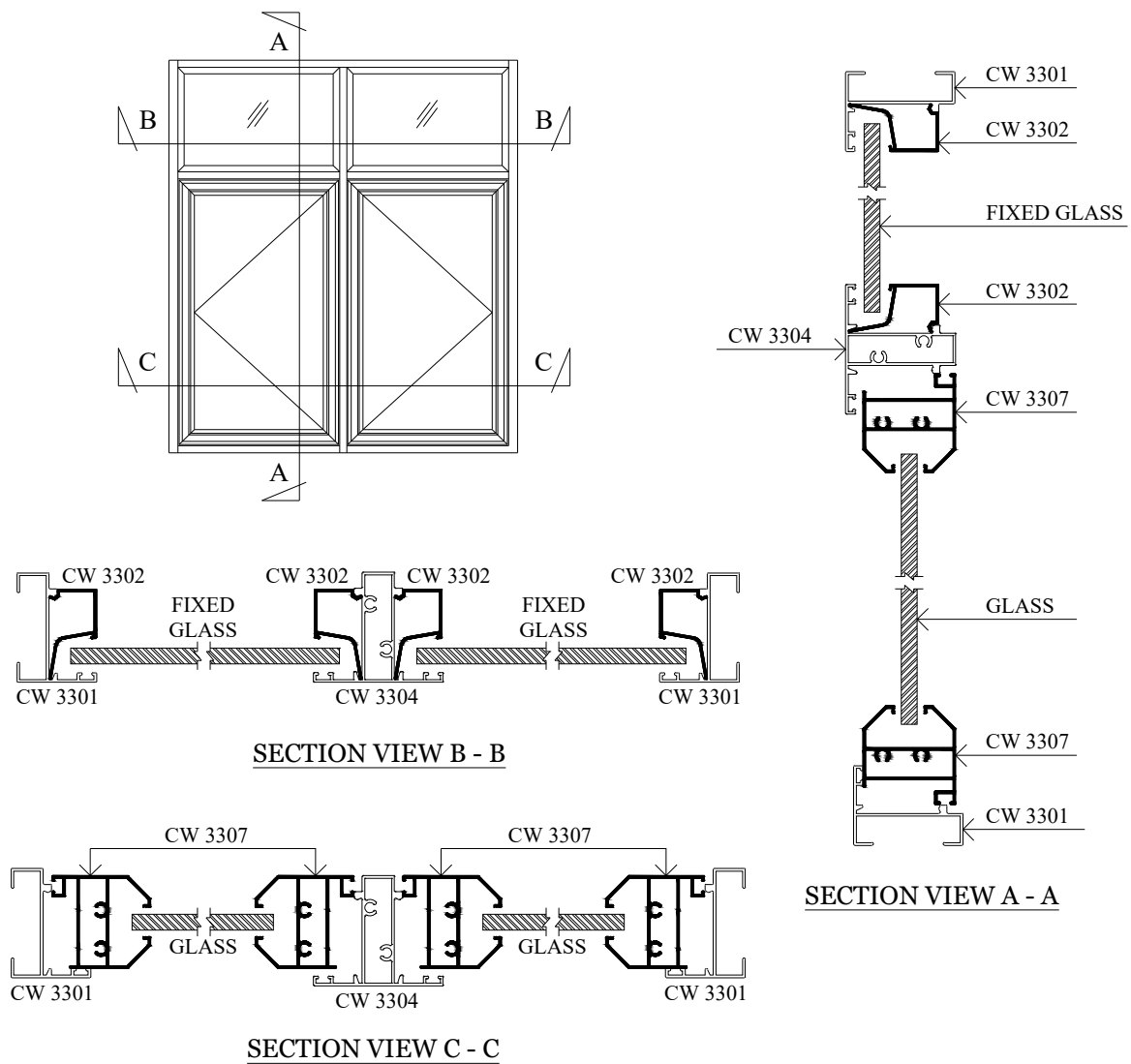

**we made aluminium into shapes ...**

*profile information*

# aluminium profiles component usage

## Casement Window - CW33 Series

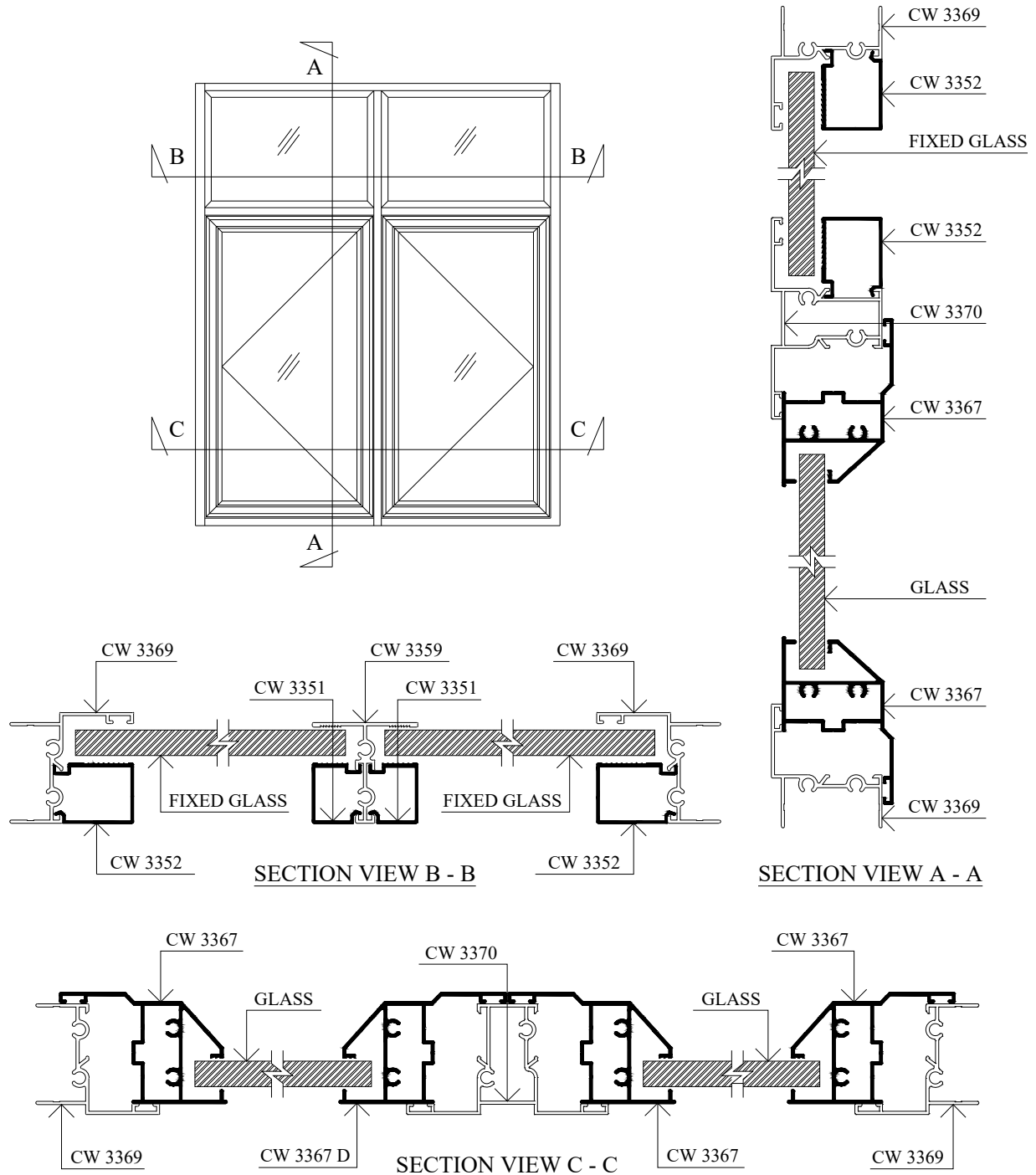

**we made aluminium into shapes ...**

*profile information*

# aluminium profiles component usage

## Casement Window - CW33 Series

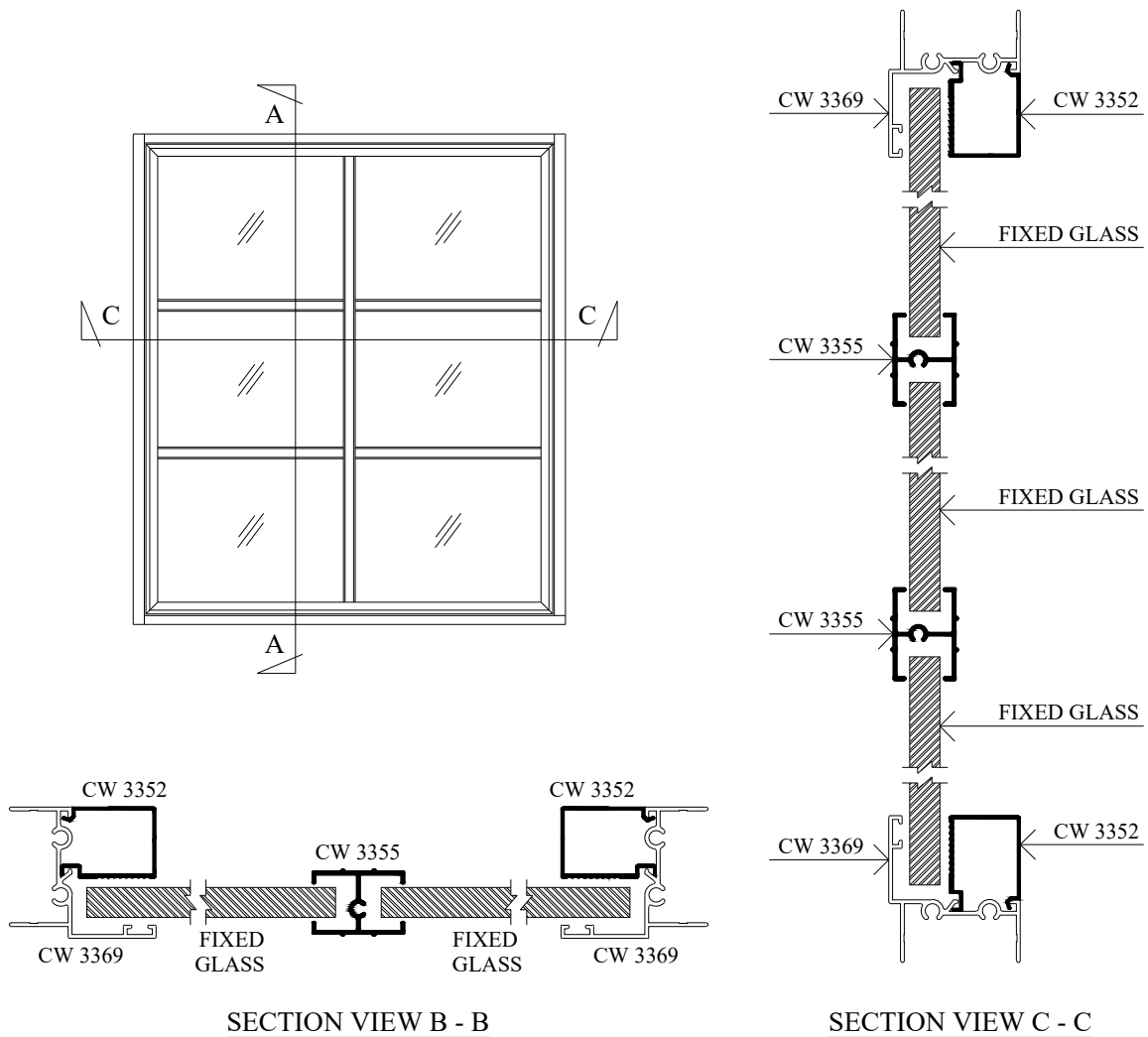

**BP Aluminium Extrusion Sdn. Bhd.**

**No.15 & 16, 1C KKIP Selatan, Industrial Zone 2, KKIP,  
88450, Jalan Sepanggar, Menggatal.**

**t : 60-88-499333, 499111 f : 60-88-499222**

**b\_p\_a\_e@yahoo.com**