

SW- Sliding Window

310 SERIES

PROFILE NO.	PICTURE OF PROFILE	WEIGHT (KG/M)	THICKNESS	PACKING IN BUNDLE (PCS)
			AREA PERIMETER	
SW 3101 J		0.635	1.30MM 344.532 MM	6
SW 3102 J		0.710	1.30MM 370.592 MM	6
SW 3103 J		0.465	1.30MM 261.623 MM	6
SW 3104 J		0.400	1.30MM 151.255 MM	12
SW 3105 J		0.563	1.30MM 211.823 MM	6
SW 3106 J		0.366	1.30MM 191.304 MM	12
SW 3107 J		0.470	1.30MM 267.961 MM	6
SW 3108 J		0.908	1.30MM 504.638 MM	4
SW 3113 J		0.596	1.35MM 324.949 MM	4
SW 3114 J		0.882	1.35MM 459.214 MM	4
SW 3115 J		0.895	1.35MM 470.073 MM	4

All Profiles are standard length 6.1 M for SKY Series

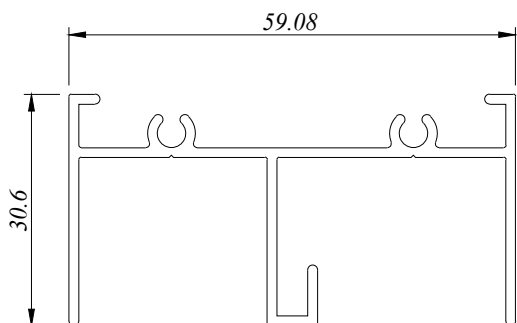

SW 3101 J
 WT : 0.635 Kg/M
 AP : 344.532 MM

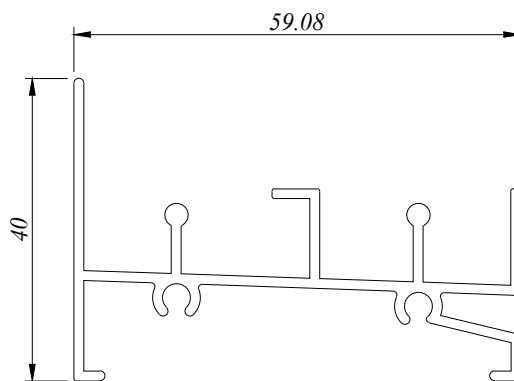

SW 3102 J
 WT : 0.710 Kg/M
 AP : 370.592 MM

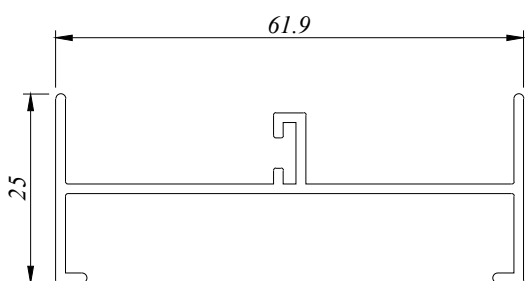

SW 3103 J
 WT : 0.465 Kg/M
 AP : 261.623 MM

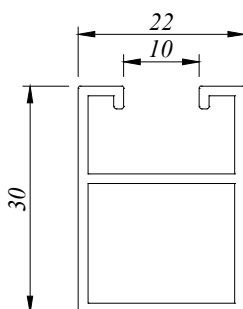

SW 3104 J
 WT : 0.400 Kg/M
 AP : 151.255 MM

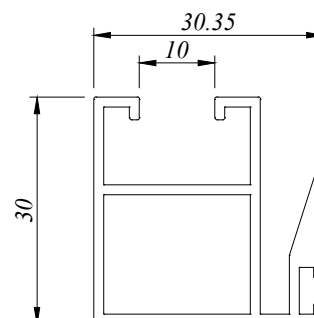

SW 3105 J
 WT : 0.563 Kg/M
 AP : 211.823 MM

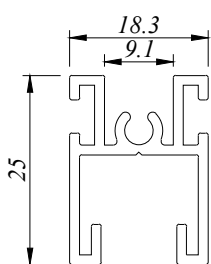

SW 3106 J
 WT : 0.366 Kg/M
 AP : 191.304 MM

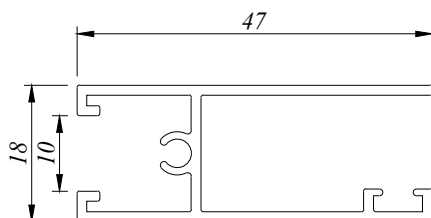

SW 3107 J
 WT : 0.470 Kg/M
 AP : 267.961 MM

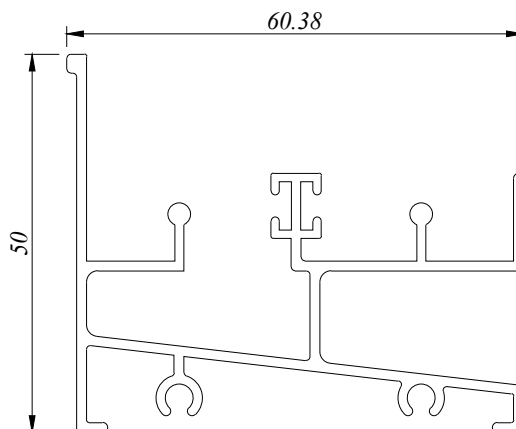

SW 3108 J
 WT : 0.908 Kg/M
 AP : 504.638 MM

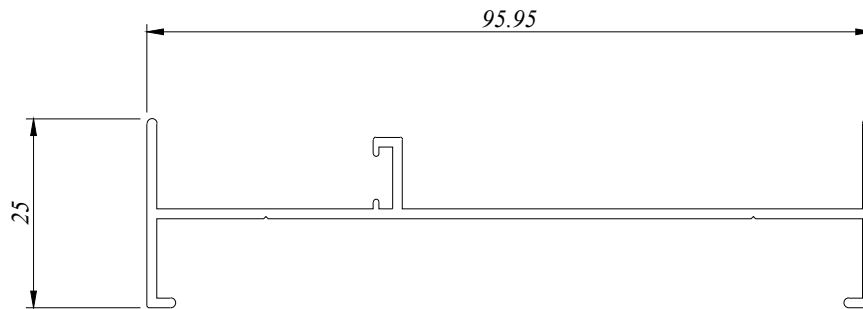

SW 3113 J
WT : 0.596 Kg/M
AP : 324.949 MM

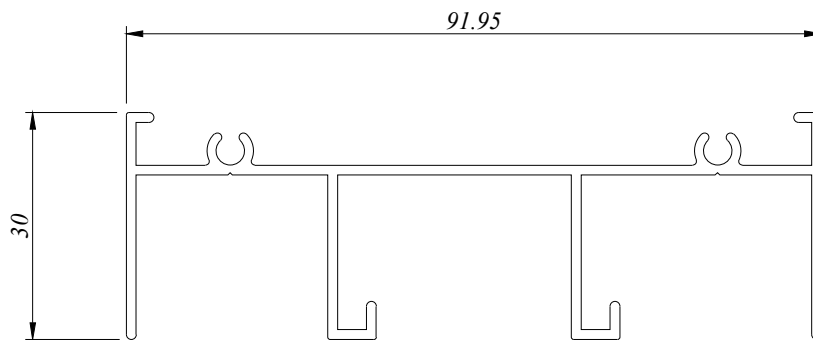

SW 3114 J
WT : 0.882 Kg/M
AP : 459.214 MM

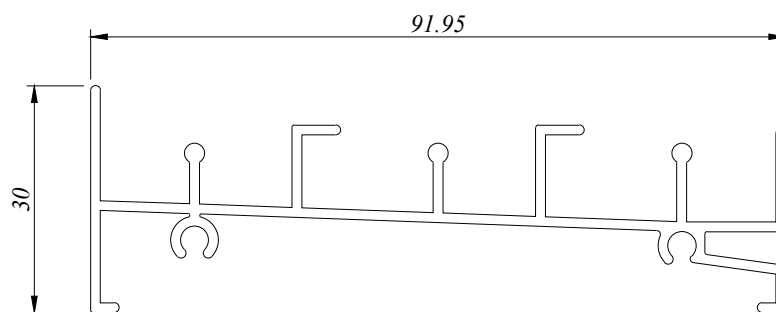

SW 3115 J
WT : 895 Kg/M
AP : 470.073 MM



BP Aluminium Extrusion Sdn. Bhd.

**No.15 & 16, 1C KKIP Selatan, Industrial Zone 2, KKIP,
88450, Jalan Sepanggar, Menggatal.**

t : 60-88-499333, 499111 f : 60-88-499222

b_p_a_e@yahoo.com